



Z8F08A28100KITG

**Z8 Encore! XP[®] F082A Series
Development Kit**

User Manual

UM018606-0109



Revision History

Each instance in Revision History reflects a change to this document from its previous revision. For more details, refer to the corresponding pages and appropriate links in the table below.

Date	Revision Level	Description	Page Number
January 2009	06	Updated Hardware section.	1
May 2008	05	Updated Introduction section. Changed 'Z8F08A28100KIT' to 'Z8F08A28100KITG'.	1
March 2008	04	Updated the new Zilog logo, implemented Style Guide, and changed ZiLOG to Zilog. Changed title to Z8 Encore! XP F082A Series Development Kit. Modified Schematics Table 2 to incorporate changes to R15 from 220 Ω to 0 Ω. Added Note 3 to the Schematics .	All
October 2005	03	F08xA Series development board, Corrected typo in MCU features list: updated schematics for board rev C.	6 , 9
February 2005	02	Introduction, Corrected Typo in development kit name.	1



Table of Contents

Introduction	1
Kit Contents	1
Hardware	1
Software (on CD-ROM)	2
Documentation	3
System Requirements	3
Installation	4
Z8 Encore! XP F082A Series Development Board	5
Introduction	5
Features	6
MCU	6
UART with IrDA Endec	7
Power and Communication Interfaces	8
External Interface Headers JP1 and JP2	8
Schematics	9
Customer Support	11

Introduction

Zilog's Z8 Encore! XP[®] F082A Series microcontroller unit (MCU) is a part of the line of Zilog's MCU products. The Z8 Encore! XP F082A Series MCU development kit (Z8F08A28100KITG) enables you to become familiar with the hardware and software tools available with this product. This kit consists of the 8 KB version of the Z8 Encore! XP development board that supports and presents the features of the Z8 Encore! XP F082A Series. This kit allows you to begin writing application software and contains all supporting documents.

This manual acquaints you with the Z8 Encore! XP F082A Series MCU development kit, and provides instructions on setting up and using the tools to start building designs and applications. Z8F082ASJ020 is the silicon used in the board. For more information, refer to *Z8 Encore! XP[®] F082A Series Product Specification (PS0228)*.

Kit Contents

The Z8 Encore! XP F082A Series MCU development kit contains the following:

Hardware

The hardware in Z8 Encore! XP F082A Series MCU development kit include:

- Z8 Encore! XP F082A Series development board
- USB Smart Cable for PC to Z8 Encore! XP[®] F082A series development board (previous versions of the development kit used a serial smart cable; for information on using the serial smart cable, refer to your original documentation)
- 5 V DC power supply



Figure 1. Z8 Encore! XP[®] F082A Series Development Kit Contents

Software (on CD-ROM)

The software in Z8 Encore! XP F082A Series MCU development kit include:

- ZDS II—Z8 Encore![®] IDE with ANSI C-Compiler
- Sample code
- Document browser
- Acrobat Reader

Documentation

The following documents are included in the Z8 Encore! XP F082A Series development kit:

- Quick Start Guide
- Z8 Encore! XP F082A Series technical documentation (on CD-ROM)
 - Development Kit User Manual
 - ZDS II—IDE User Manual
 - eZ8 CPU User Manual
 - Application Notes

The sample code is installed with ZDS II and is located in the <installation directory>\samples in the disk drive.

The documentation can be installed with the **DemoShield** interface or viewed on the CD-ROM using the **DemoShield** menus and a PDF reader. A copy of the Acrobat installer is provided on the CD-ROM and can be installed from the **DemoShield** install screen. After installing the documentation, Windows Explorer can be used to select any document to be viewed with PDF file viewer.

System Requirements

An IBM PC (or compatible computer) with the following minimum configurations are required:

- Microsoft Windows XP Professional SP1/Windows 2000 SP3/Windows NT 4.0 SP6/Windows 98 SE
- Pentium II/233 MHz processor or higher up to Pentium IV, 2.8 GHz
- 96 MB RAM or more
- 25 MB hard disk space or more
- Super VGA video adapter



- CD-ROM
- One or more RS-232 communication ports

Installation

For details on installation and setup of the Z8 Encore! XP F082A Series development kit, refer to *Z8 Encore! XP[®]/Z8 Encore![®] Development Kits Quick Start Guide (QS0043)*.

Z8 Encore! XP F082A Series Development Board

Introduction

Zilog's Z8 Encore! XP[®] F082A Series development board is a development and prototyping board for the Z8 Encore! XP F082A Series MCU. The board provides you with a tool to evaluate features of Z8 Encore! XP F082A Series MCU, and to start developing an application before building the hardware.

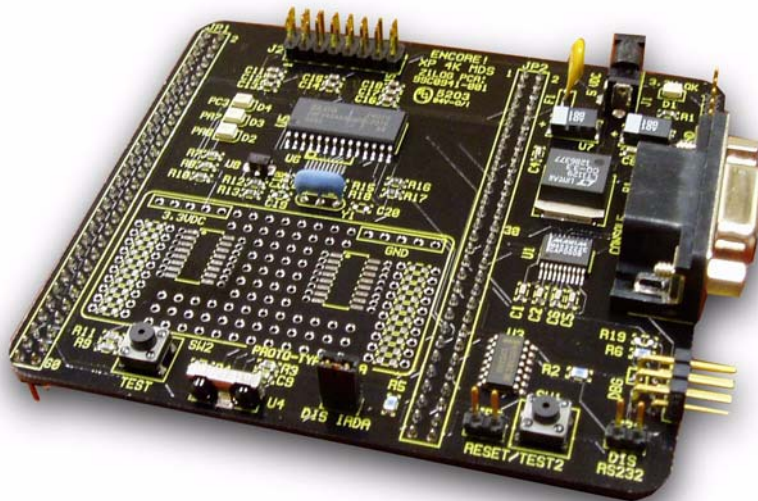

Figure 2. Z8 Encore! XP[®] F082A Series Development Board

Features

The features of Z8 Encore! XP[®] F082A Series development board include:

- Z8 Encore! XP MCU (28-pin SOIC)
- 3 LEDs
- RS-232 interface
- IrDA transceiver
- Two pushbuttons, RESET and TEST
- 5 V DC power connector
- On-Chip Debugger interface
- 20 MHz Ceramic Oscillator (Y1)
- Header for ADC input
- Prototyping area
- External interface connectors JP1 and JP2
- 2.7 V–3.6 V operating voltage with 5 V-tolerant inputs

MCU

The Z8 Encore! XP F082A Series MCU is a member of the family of Zilog MCU products based on the 8-bit eZ8 core CPU. The Flash in-circuit programming capability allows for faster development time and program changes in the field. The eZ8 core CPU is upward compatible with existing Z8[®] instructions. The rich peripheral set of the Z8 Encore! XP F082A Series makes it suitable for a variety of applications including motor control, security systems, home appliances, personal electronic devices, and sensors.

The development board contains circuitry to support and present all the features of the Z8 Encore! XP F082A Series. The key features of the Z8 Encore! XP F082A Series include:

- eZ8 core CPU
- 8 KB Flash memory with in-circuit programming capability
- 1 KB register RAM
- 8-channel, 10-bit Analog-to-Digital Converter (ADC)
- Full-duplex UART
- Infrared Data Association (IrDA)-compliant infrared encoder/decoder
- Two 16-bit timers with capture, compare, and PWM capability
- Watchdog Timer (WDT) with internal RC oscillator
- Eleven (20-pin package) or nineteen (28-pin package) I/O pins
- Programmable priority interrupts
- On-Chip Debugger
- Voltage Brownout (VBO) Protection
- Power-On Reset (POR)
- 2.7 V–3.6 V operating voltage with 5 V-tolerant inputs
- Operating temperatures: 20 °C ±10 °C

For further information on the Z8 Encore![®] family of devices, refer to *Z8 Encore! XP[®] F082A Series Product Specification (PS0228)*, available for download at www.zilog.com.

UART with IrDA Endec

Z8 Encore! XP F082A Series (component U5) contains a fully-functional, high-performance UART with Infrared Encoder/Decoder (ENDEC). The Infrared Endec is integrated with an on-chip UART allowing easy

communication between the Z8 Encore! XP F082A Series and IrDA transceivers. Infrared communication provides secure, reliable, low-cost, point-to-point communication between PCs, PDAs, cell phones, printers, and other infrared enabled devices.

Power and Communication Interfaces

[Table 1](#) lists jumper information concerning the shunt status, functions, devices and defaults affected of jumpers JP3 and JP4.

Table 1. Jumpers JP3 and JP4

Jumper	Status	Device Affected	Status	Default
JP3*	OUT	RS-232 interface	Enabled	X
JP3	IN	RS-232 interface	Disabled	
JP4*	OUT	IrDA interface	Enabled	
JP4	IN	IrDA interface	Disabled	X
JP5	OUT	U5 RESET/ PD0	PD0 (GPIO)	X
JP5	IN	U5 RESET/ PD0	RESET when SW1 pressed	
*These jumpers must not be OUT at the same time.				

External Interface Headers JP1 and JP2

External interface headers JP1 and JP2 are displayed in [Schematics](#) on page 9.

Schematics

Figure 3 and Figure 4 on page 10 display the schematics for Z8 Encore! XP F082A Series development board.

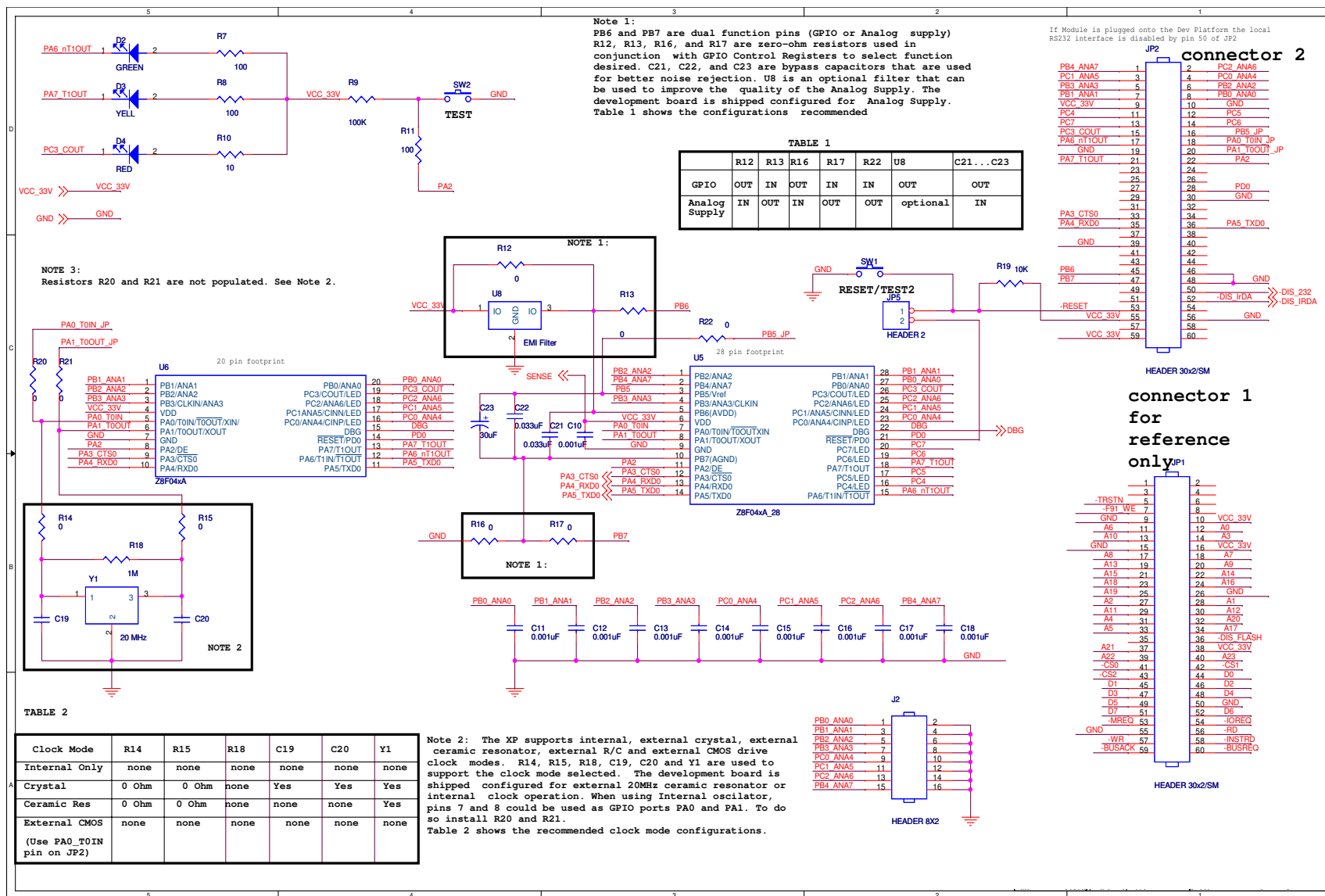

Figure 3. Schematic, Z8 Encore! XP[®] F082A Series MCU Development Board

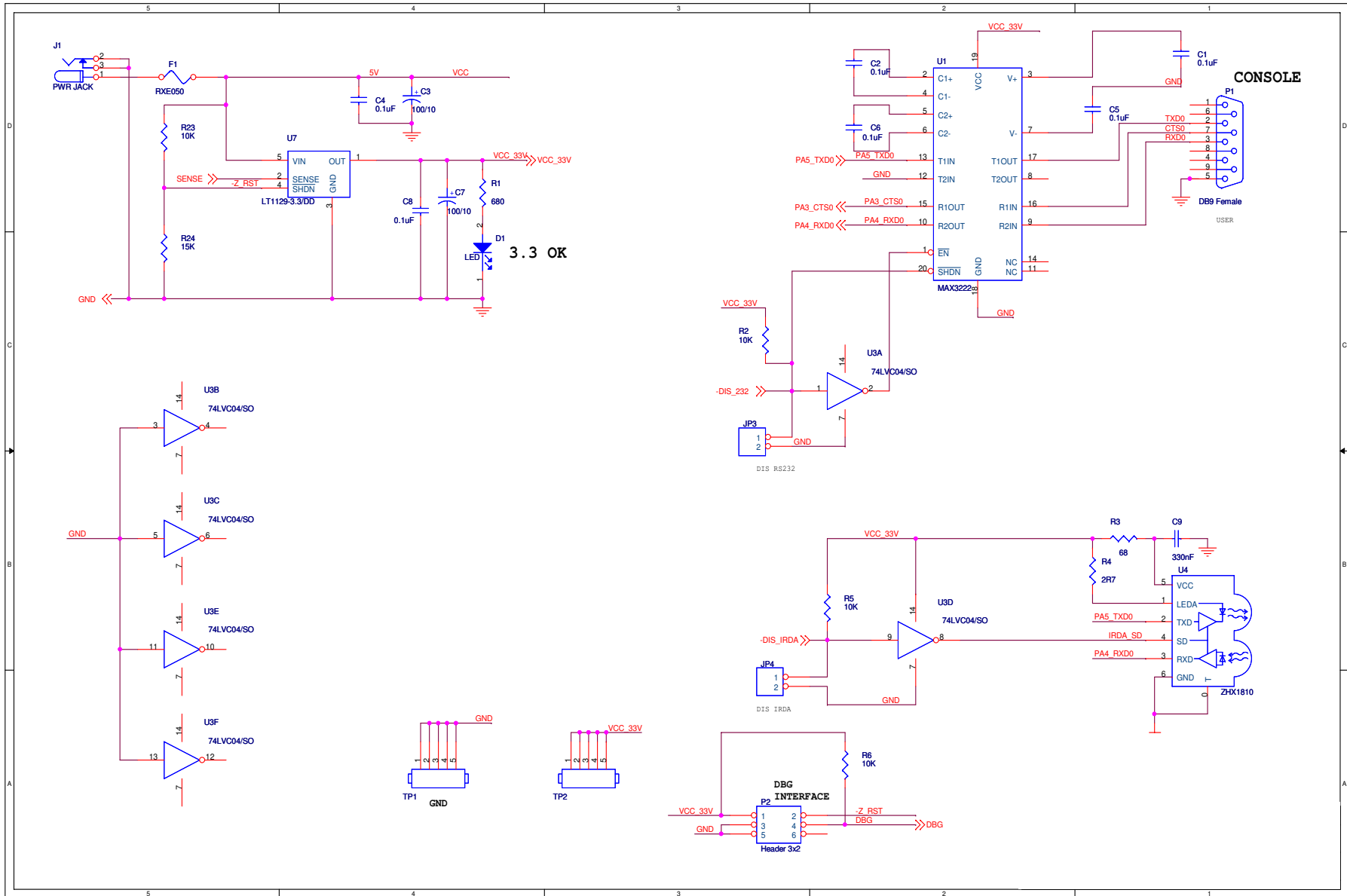

Figure 4. Schematic, Z8 Encore! XP[®] F082A Series MCU Development Board



Customer Support

For answers to technical questions about the product, documentation, or any other issues with Zilog's offerings, please visit Zilog's Knowledge Base at <http://www.zilog.com/kb>.

For any comments, detail technical questions, or reporting problems, please visit Zilog's Technical Support at <http://support.zilog.com>.



Warning: DO NOT USE IN LIFE SUPPORT

LIFE SUPPORT POLICY

ZILOG'S PRODUCTS ARE NOT AUTHORIZED FOR USE AS CRITICAL COMPONENTS IN LIFE SUPPORT DEVICES OR SYSTEMS WITHOUT THE EXPRESS PRIOR WRITTEN APPROVAL OF THE PRESIDENT AND GENERAL COUNSEL OF ZILOG CORPORATION.

As used herein

Life support devices or systems are devices which (a) are intended for surgical implant into the body, or (b) support or sustain life and whose failure to perform when properly used in accordance with instructions for use provided in the labeling can be reasonably expected to result in a significant injury to the user. A critical component is any component in a life support device or system whose failure to perform can be reasonably expected to cause the failure of the life support device or system or to affect its safety or effectiveness.

Document Disclaimer

©2009 by Zilog, Inc. All rights reserved. Information in this publication concerning the devices, applications, or technology described is intended to suggest possible uses and may be superseded. ZILOG, INC. DOES NOT ASSUME LIABILITY FOR OR PROVIDE A REPRESENTATION OF ACCURACY OF THE INFORMATION, DEVICES, OR TECHNOLOGY DESCRIBED IN THIS DOCUMENT. ZILOG ALSO DOES NOT ASSUME LIABILITY FOR INTELLECTUAL PROPERTY INFRINGEMENT RELATED IN ANY MANNER TO USE OF INFORMATION, DEVICES, OR TECHNOLOGY DESCRIBED HEREIN OR OTHERWISE. The information contained within this document has been verified according to the general principles of electrical and mechanical engineering.

Z8, Z8 Encore!, and Z8 Encore! XP are registered trademarks of Zilog, Inc. All other product or service names are the property of their respective owners.