



Universal Motor Control with Z8 Encore! XP[®] 8-Pin Highly Integrated Microcontroller

AN023503-0608



Abstract

This Application Note discusses programmable speed control of a Universal Motor using Zilog's Z8 Encore! XP[®] 8-pin microcontroller unit (MCU). In this application, based on the array of innovative on-chip integrated digital and analog hardware blocks, speed control requires a minimum set of external components and firmware development.

- **Note:** *The source code file associated with this application note, AN0235-SC01.zip is available for download at www.zilog.com.*

Motor control attributes including synchronization of MCU output signals based on the Zero Crossing of the AC line voltage and Speed Control are also discussed in this document.

- **Note:** *This application discussed in this document is tested with ZDS II version 4.9.6. Subsequent releases of ZDS II may require you to modify code supplied with this Application Note.*

Z8 Encore![®] Flash Microcontrollers

Z8 Encore! products are based on the eZ8[™] CPU and introduce Flash memory to Zilog's extensive line of 8-bit MCU. Flash memory in-circuit programming capability allows for faster development time and program changes in the field. The high-performance register-to-register based architecture of the eZ8 core maintains backward compatibility with Zilog's Z8[®] MCU.

Z8 Encore! MCUs combine a 20 MHz core with Flash memory, linear-register SRAM, and an extensive array of on-chip peripherals. These peripherals make the Z8 Encore! MCU suitable for a variety of applications including motor control, security systems, home appliances, personal electronic devices, and sensors.

MDS GP Application Board Overview

Zilog's general-purpose modular development system application board (MDS GP) is a platform for designing innovative applications using the Z8 Encore! and eZ80Acclaim![®] MDS-compatible microcontroller modules. The MDS GP application board features a character LCD display, a keypad matrix, 512 KB of fast SRAM, two relays with a terminal block, six high-drive outputs with terminal blocks, and a RS-485 interface/screw terminal block. Battery operation is supported to add portability and mobility to your design.

The MDS GP application board acts as the perfect foundation for innovative development ideas with compatible connectors for the optional Trimble Lasso SQ GPS module, the Maxstream Wireless Data module (900 MHz or 2.4 GHz), and the Dinsmore 1490 Digital Compass, along with a large breadboard area.

Discussion

The Z8 Encore! XP Flash MCU is based on Zilog's advanced eZ8 8-bit CPU core and is ideally suited for implementation in Universal Motor control systems. Target applications include home appliances, power tools, and industrial automation.

Figure 1 displays a block diagram of the device. Here, the rich set of on-chip integrated analog peripherals allows for realization of a number of

enhanced control features, and also provides for low overall system cost.

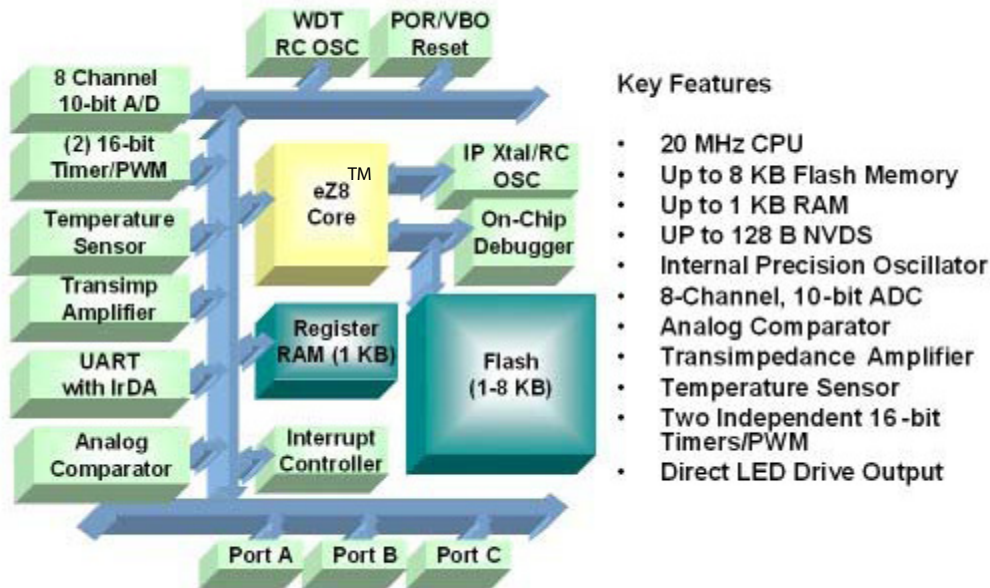

Figure 1. Block Diagram of Z8 Encore! XP[®] Flash MCU

The 10-bit analog-to-digital converter (ADC) provides for data conversion of up to eight single-ended/differential channels with the choice of 1x or 20x differential input gain. Also, for high precision current measurements, an integrated on-chip transimpedance amplifier is integrated in the ADC module, eliminating the need for an additional external component.

Along with the multi-channel ADC, the device's two enhanced 16-bit timer blocks featuring PWM and Capture and Compare capability can be used to operate two loads (motors) simultaneously. The direct LED drive output can be used to trigger LEDs at the onset of a pre-defined event, without the need for additional hardware. Other features include the integrated analog comparator, the Fail-Safe oscillator mechanism providing for reliable

operation, an on-chip integrated temperature sensor, and up to 128 B of NVDS.

Theory of Operation

Universal motors are used in a variety of applications. These motors require relatively simple electronic drive circuit topologies and exhibit good power density (power/weight ratio) characteristics. Typical applications that use Universal motors include portable power tools, food processors, and mixers.

This section describes the motor's key control attributes such as Speed Control and determination of the AC line's Zero Crossing characteristics aimed at subsequent synchronization of the MCU output signals.

Figure 2 displays the block diagram of the Universal motor system. Figure 3 on page 4 displays the Universal motor control application board. In reference to this system, ramping up of the power delivered to the motor is realized via controlling the triggering/firing angle of the TRIAC using a single I/O output of the MCU.

For controlling the motor speed, the firing angle of TRIAC is to be synchronized with the AC line voltage, thus detecting the time instants for zero crossing of AC line voltage. In this case, the on-chip integrated analog comparator is used.

Figure 4 on page 5 displays the motor voltage for different TRIAC firing angles.

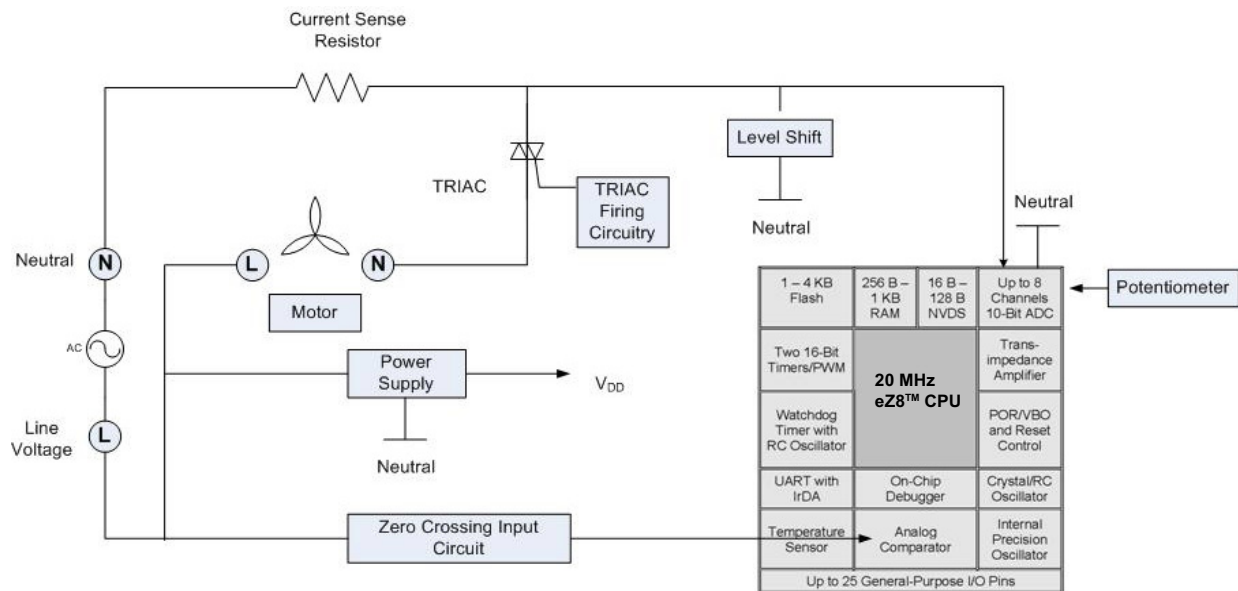

Figure 2. Block Diagram of Universal Motor Control System

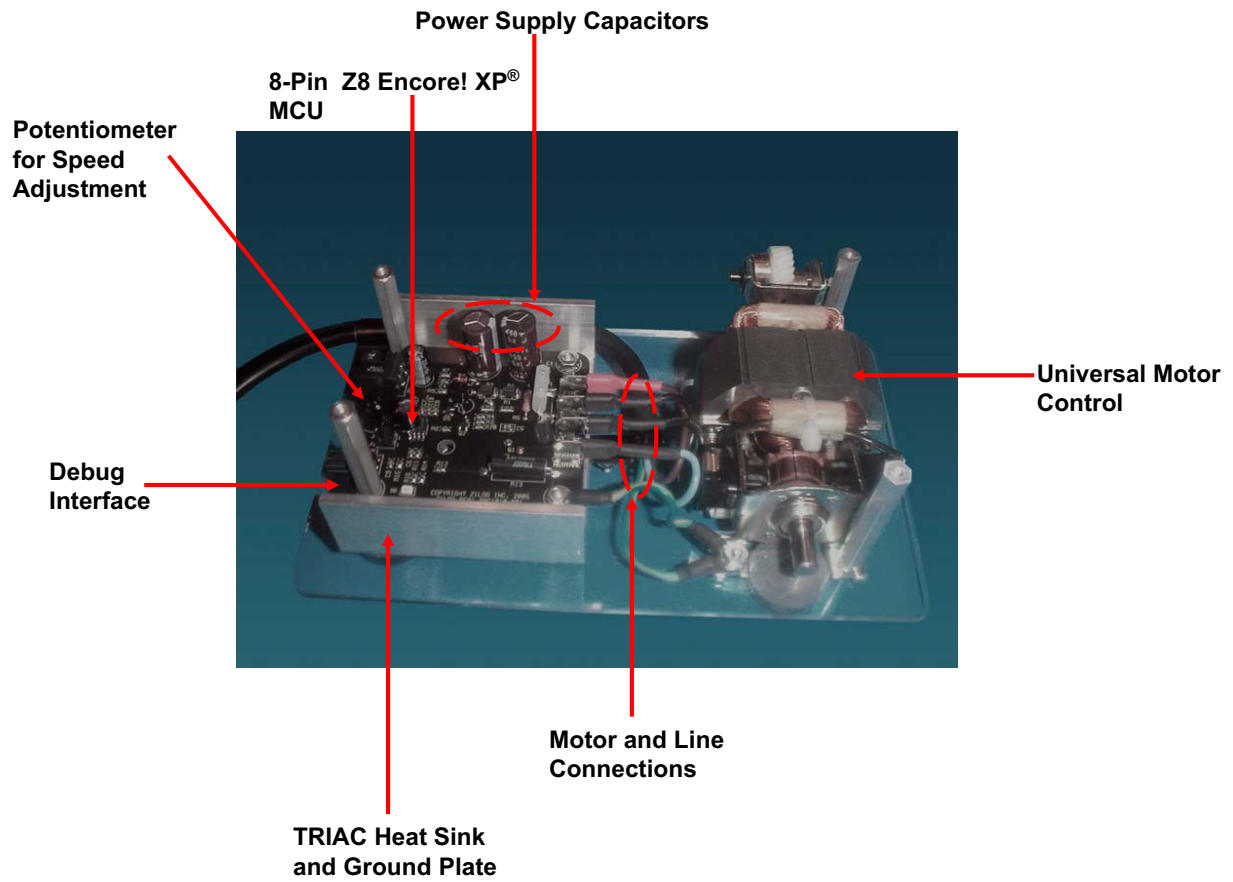

Figure 3. Universal Motor Control Application Board

Summary

This Application Note demonstrates the use of the Z8 Encore! XP! MCU for Universal motor control applications. The MCU's wide array of innovative, integrated digital and analog modules result in optimized control of the motor speed along with fault protection during an overload condition. In addition, on-chip integration of these features provides for reduced system cost and faster development cycle time.

References

The documents associated with Z8 Encore! XP[®] available on www.zilog.com are provided below:

- Z8 Encore! XP[®] F082A Series Product Brief (PB0136)
- Errata for Z8 Encore! XP[®] F082A Series Product Update (UP0069)

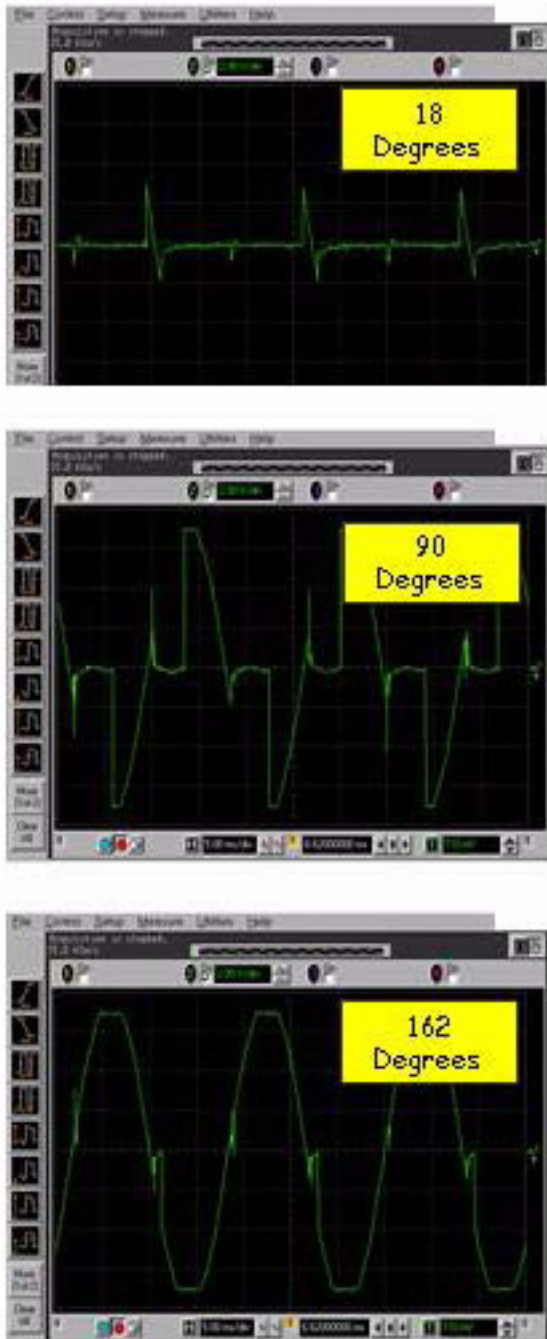

Figure 4. Motor Voltage: 18, 90, and 162 Degree TRIAC Firing Angles

Appendix A—Glossary

Definitions for terms and abbreviations used in this Application Note that are not commonly used are listed [Table 1](#).

Table 1. Glossary

Term/Abbreviation	Definition
ADC	Analog-to-Digital Converter
MCU	Microcontroller unit
MDS GP	General-purpose modular development system (application board)
NVDS	Non Volatile Data Storage
PWM	Pulse Width Modulation

Appendix B—Schematics

Appendix B displays the schematics of Z8 Encore! XP Universal Motor Control reference design.

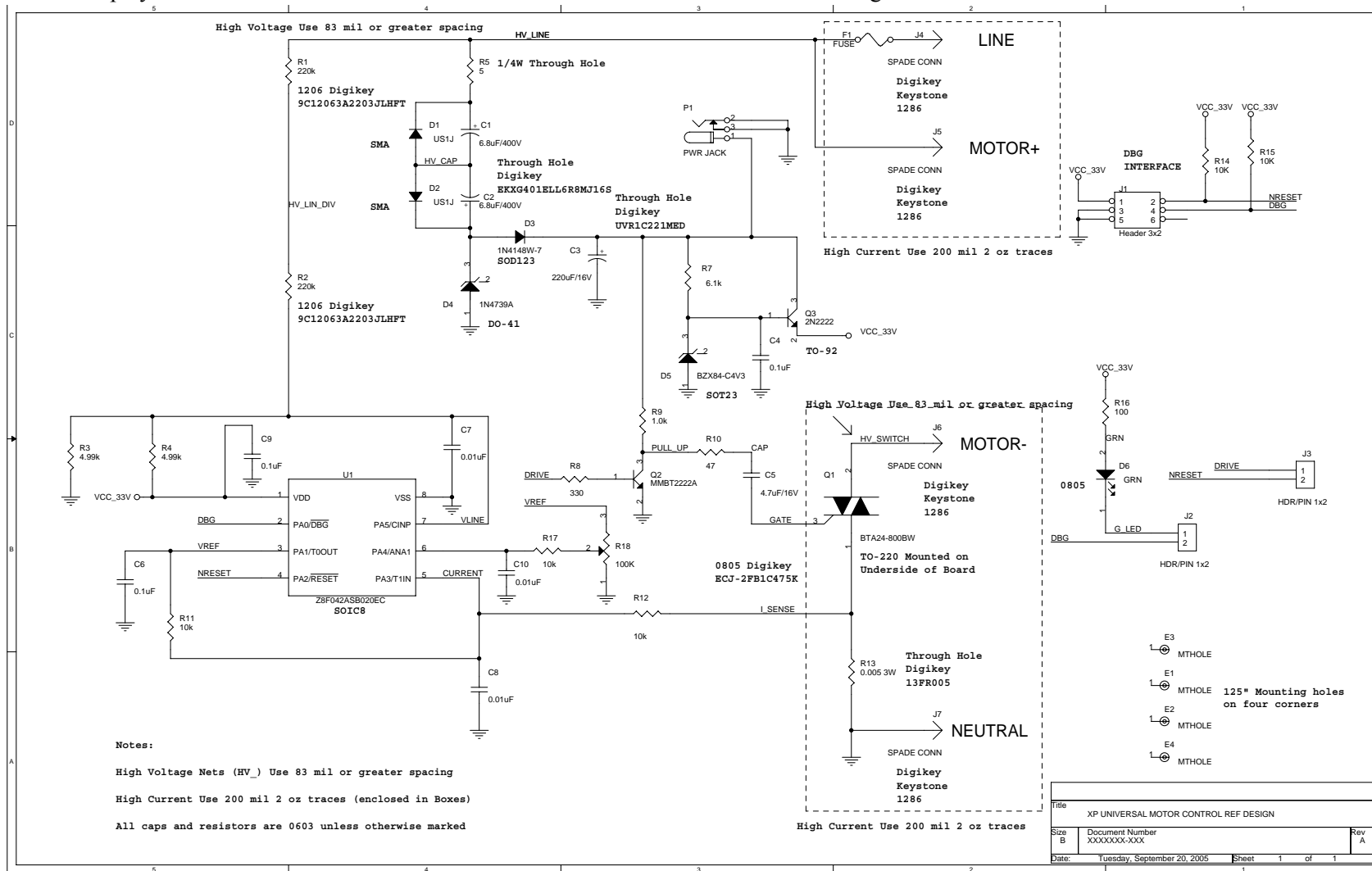

Figure 5. Z8 Encore! XP Universal Motor Control Reference Design



Warning: DO NOT USE IN LIFE SUPPORT

LIFE SUPPORT POLICY

ZILOG'S PRODUCTS ARE NOT AUTHORIZED FOR USE AS CRITICAL COMPONENTS IN LIFE SUPPORT DEVICES OR SYSTEMS WITHOUT THE EXPRESS PRIOR WRITTEN APPROVAL OF THE PRESIDENT AND GENERAL COUNSEL OF ZILOG CORPORATION.

As used herein

Life support devices or systems are devices which (a) are intended for surgical implant into the body, or (b) support or sustain life and whose failure to perform when properly used in accordance with instructions for use provided in the labeling can be reasonably expected to result in a significant injury to the user. A critical component is any component in a life support device or system whose failure to perform can be reasonably expected to cause the failure of the life support device or system or to affect its safety or effectiveness.

Document Disclaimer

©2008 by Zilog, Inc. All rights reserved. Information in this publication concerning the devices, applications, or technology described is intended to suggest possible uses and may be superseded. ZILOG, INC. DOES NOT ASSUME LIABILITY FOR OR PROVIDE A REPRESENTATION OF ACCURACY OF THE INFORMATION, DEVICES, OR TECHNOLOGY DESCRIBED IN THIS DOCUMENT. ZILOG ALSO DOES NOT ASSUME LIABILITY FOR INTELLECTUAL PROPERTY INFRINGEMENT RELATED IN ANY MANNER TO USE OF INFORMATION, DEVICES, OR TECHNOLOGY DESCRIBED HEREIN OR OTHERWISE. The information contained within this document has been verified according to the general principles of electrical and mechanical engineering.

eZ8, Z8, Z8 Encore!, Z8 Encore! XP, and eZ80Acclaim! are trademarks or registered trademarks of Zilog, Inc. All other product or service names are the property of their respective owners.