

# 3 PHASE POWER STAGE

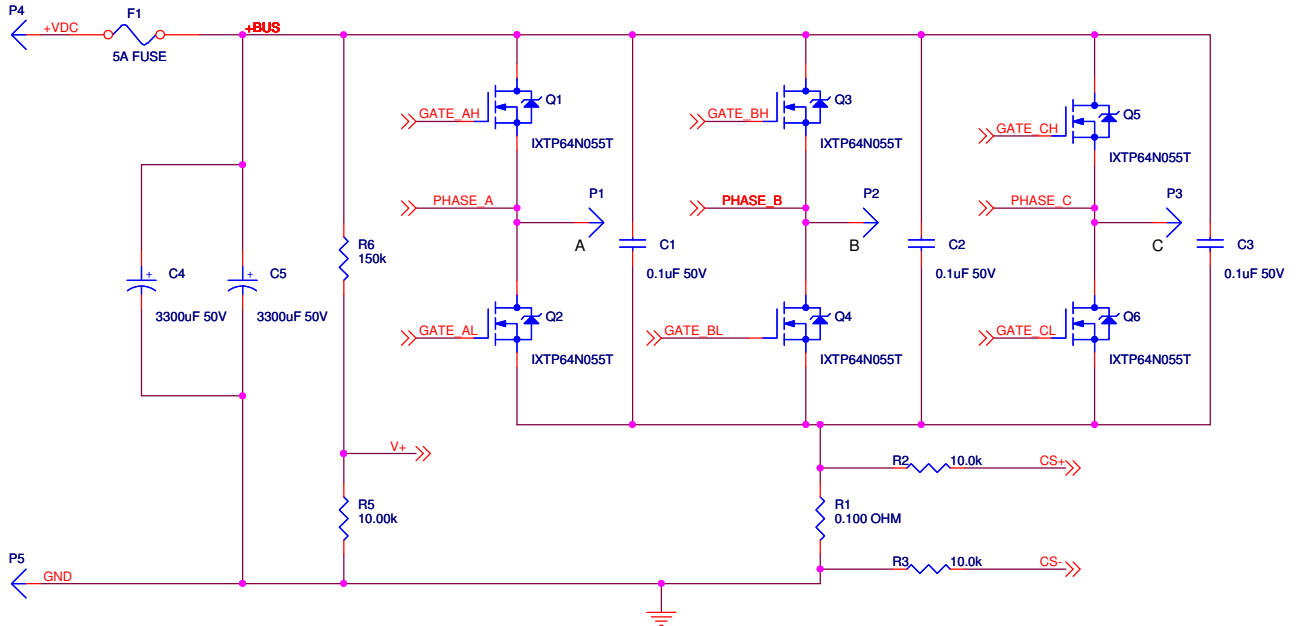

# HEATSINK TEMP SENSOR

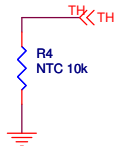

Title		
3 PHASE MOTOR CONTROL APPLICATION BOARD		
Size	Document Number	Rev
A	96C0960-001	C
Date:	Monday, April 26, 2010	Sheet 1 of 3

### BEMF DIVIDERS

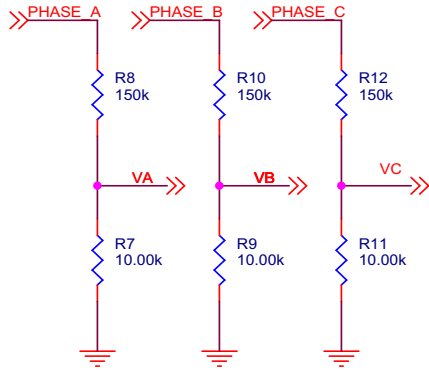

### 12V SUPPLY

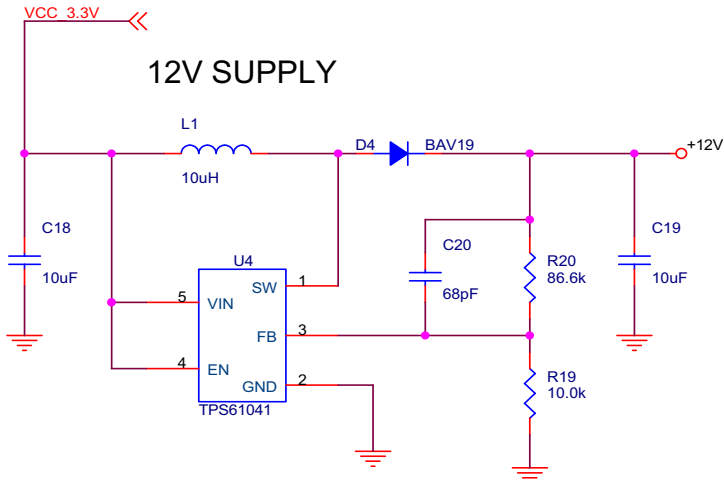

### GATE DRIVE

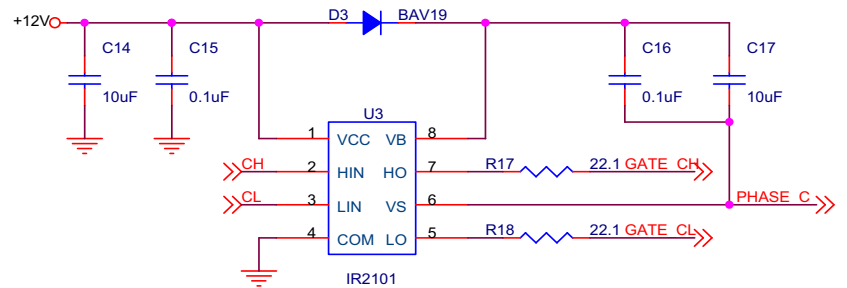
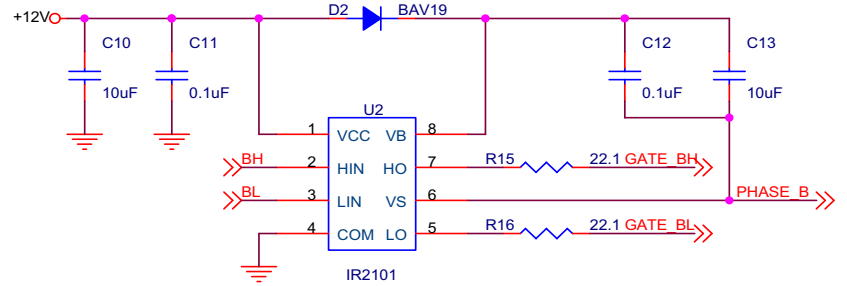
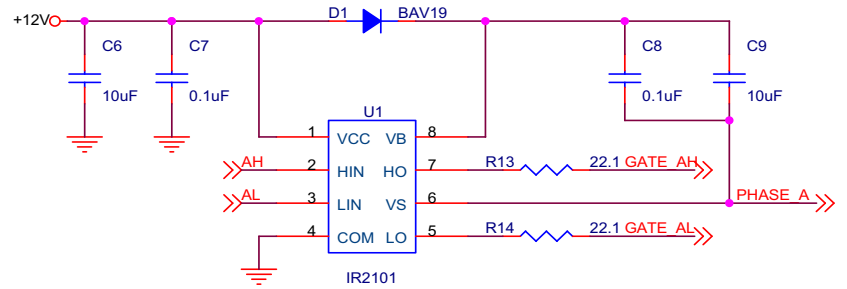

Title		
3 PHASE MOTOR CONTROL APPLICATION BOARD		
Size A	Document Number	Rev B
	96C0960-001	
Date:	Wednesday, June 08, 2005	Sheet 2 of 3

## UNUSED

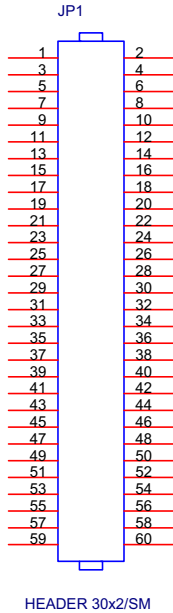

## POWER INTERFACE

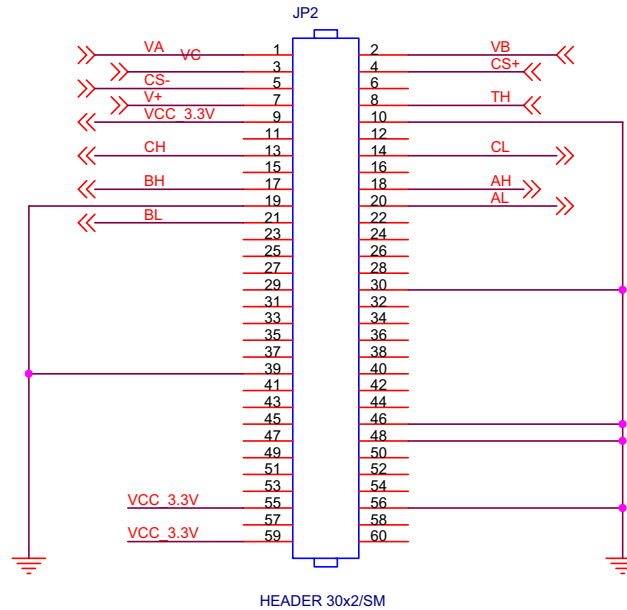

Title		
3 PHASE MOTOR CONTROL APPLICATION BOARD		
Size	Document Number	Rev
A	96C0960-001	B
Date:	Wednesday, June 08, 2005	Sheet 3 of 3



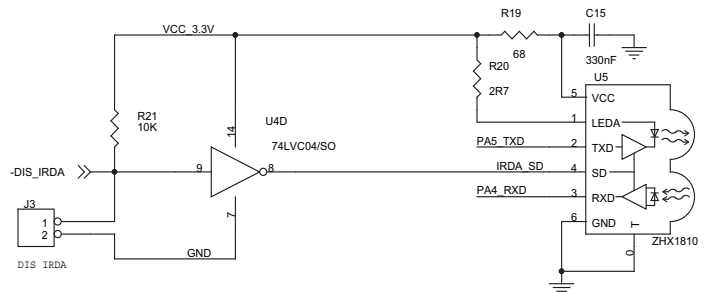
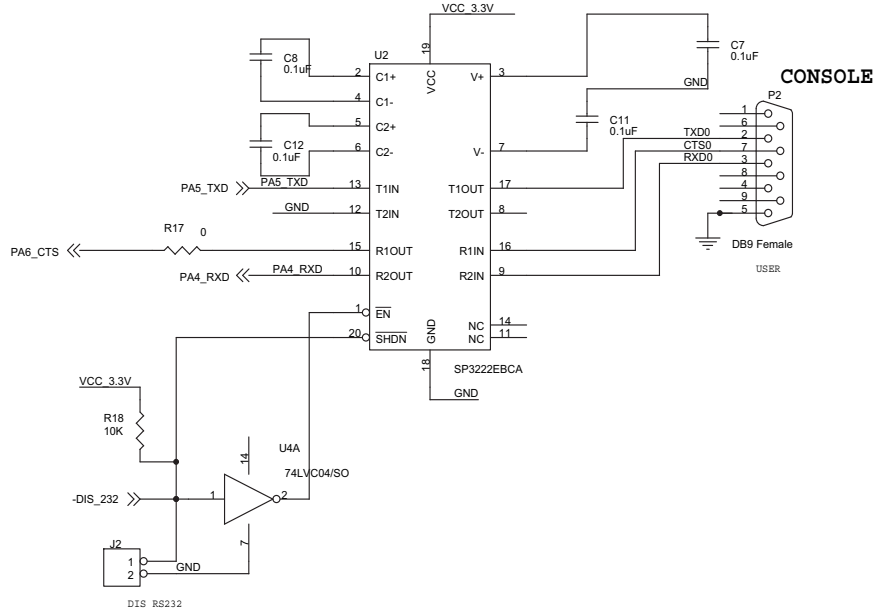
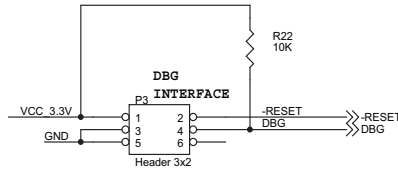
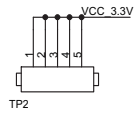
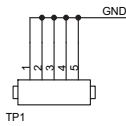
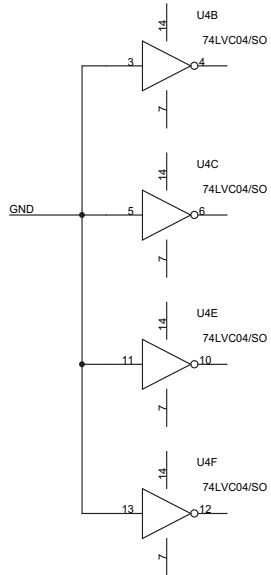
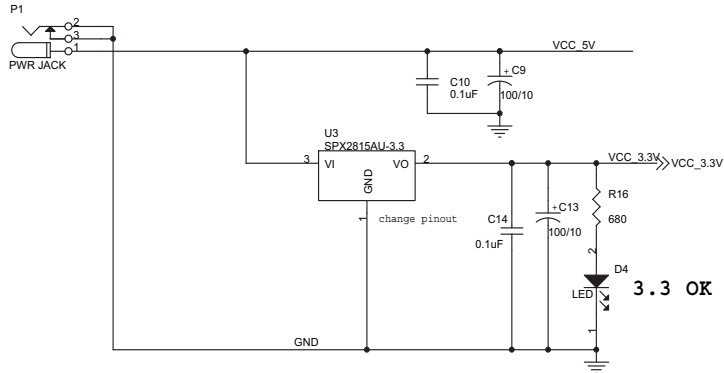

POWER AND COMMUNICATIONS

Title		
SCHEMATIC, Z8FMC16 MDS MODULE		
Size	Document Number	Rev
B	96C0987-001	B
Date:	Tuesday, June 21, 2005	Sheet 2 of 2