

Note 1:
 PB6 and PB7 are dual function pins (GPIO or Analog supply)
 R12, R13, R16, and R17 are zero-ohm resistors used in conjunction with GPIO Control Registers to select function desired. C21, C22, and C23 are bypass capacitors that are used for better noise rejection. U8 is an optional filter that can be used to improve the quality of the Analog Supply. The development board is shipped configured for Analog Supply. Table 1 shows the configurations recommended

TABLE 1

	R12	R13	R16	R17	R22	U8	C21...C23
GPIO	OUT	IN	OUT	IN	IN	OUT	OUT
Analog Supply	IN	OUT	IN	OUT	OUT	optional	IN

If Module is plugged onto the Dev Platform the local RS232 interface is disabled by pin 50 of JP2

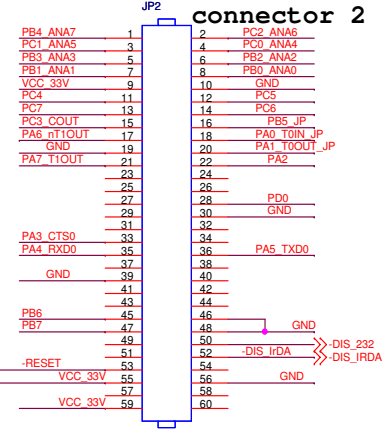

NOTE 3:
 Resistors R20 and R21 are not populated. See Note 2.

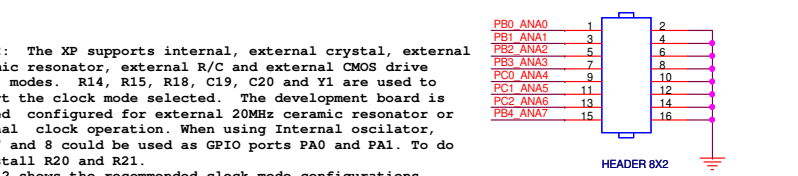
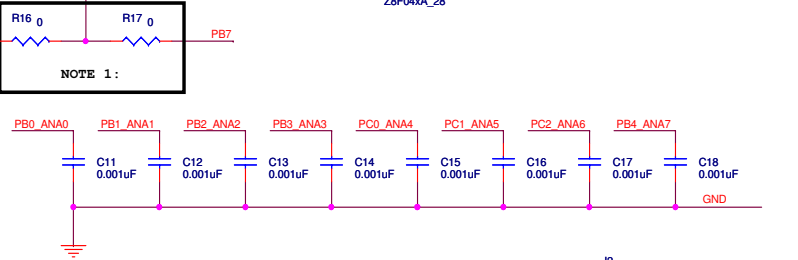
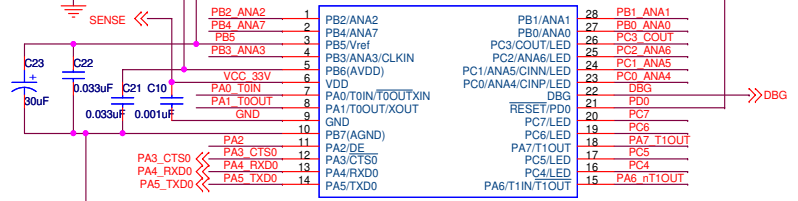
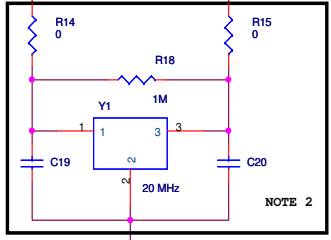
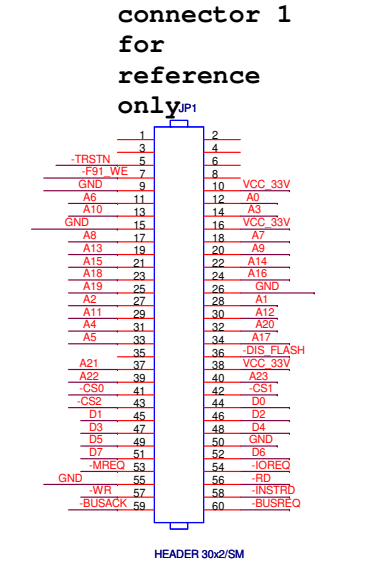
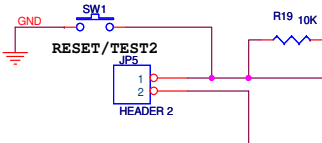
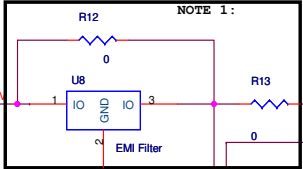
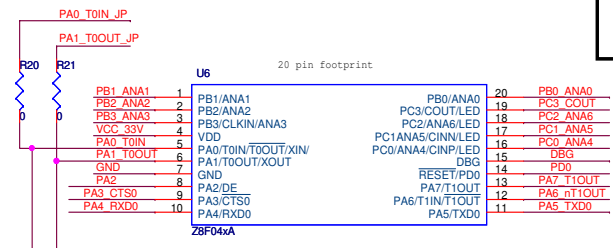
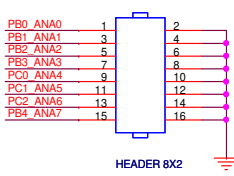
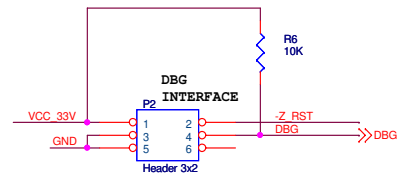
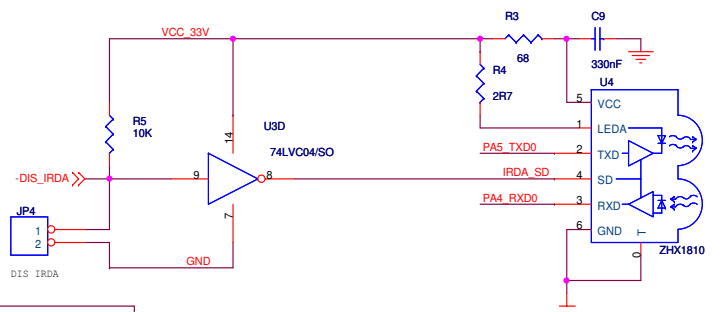
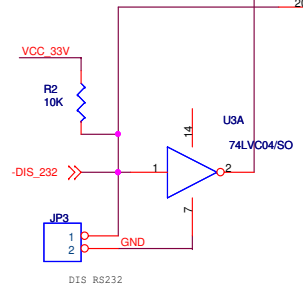
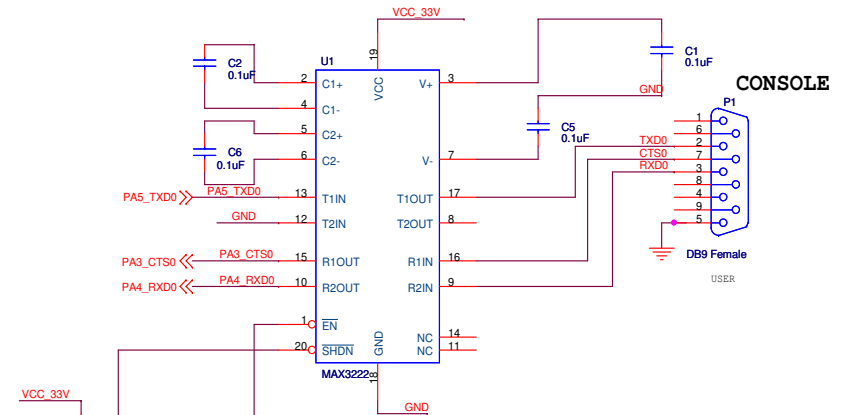
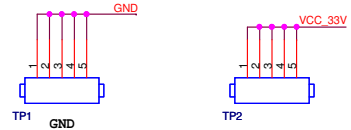
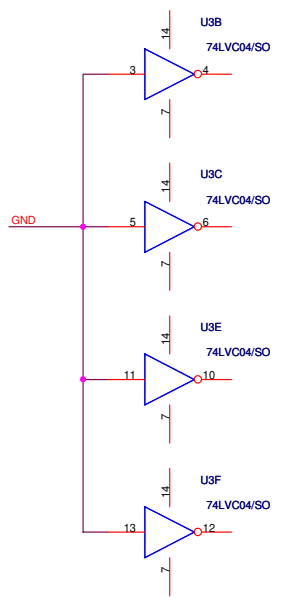
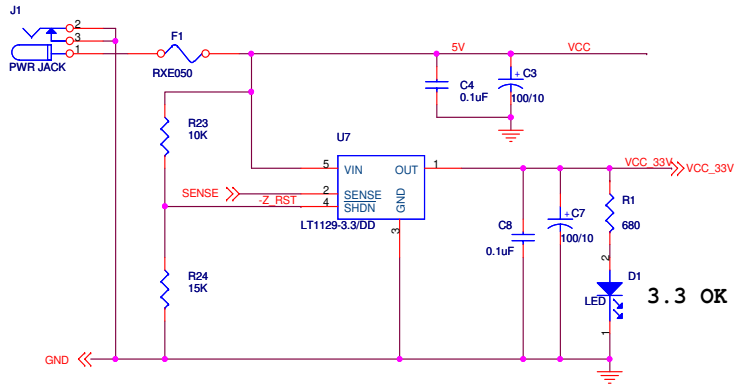

TABLE 2

Clock Mode	R14	R15	R18	C19	C20	Y1
Internal Only	none	none	none	none	none	none
Crystal	0 Ohm	0 Ohm	none	Yes	Yes	Yes
Ceramic Res	0 Ohm	0 Ohm	none	none	none	Yes
External CMOS (Use PA0_T0IN pin on JP2)	none	none	none	none	none	none

Note 2: The XP supports internal, external crystal, external ceramic resonator, external R/C and external CMOS drive clock modes. R14, R15, R18, C19, C20 and Y1 are used to support the clock mode selected. The development board is shipped configured for external 20MHz ceramic resonator or internal clock operation. When using internal oscillator, pins 7 and 8 could be used as GPIO ports PA0 and PA1. To do so install R20 and R21.
 Table 2 shows the recommended clock mode configurations.





CONSOLE

