

Schematic Diagrams

Figures 7 through 9 display schematics for the 3-Phase Motor Control Application Board.

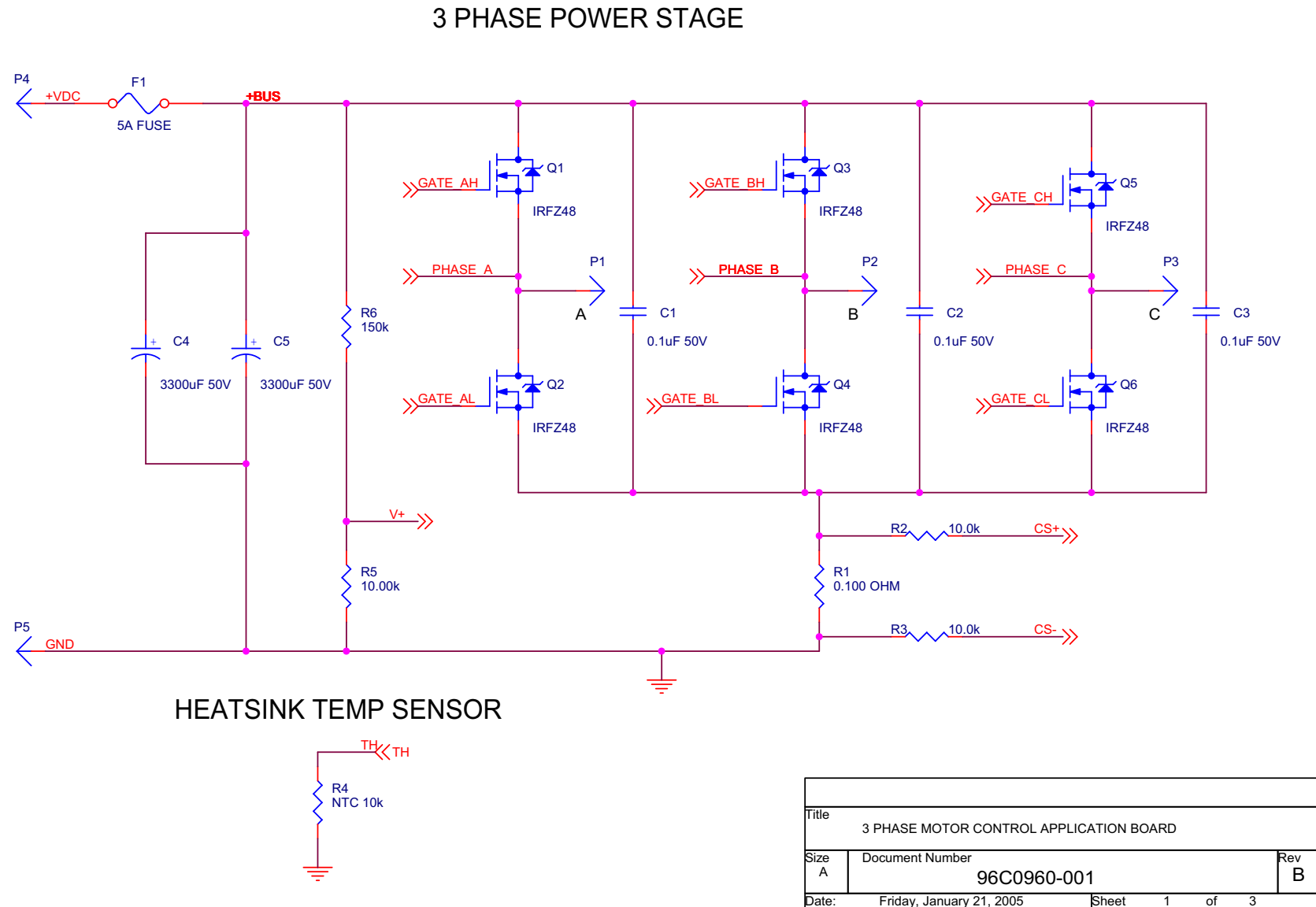

Figure 7. 3-Phase Motor Control Application Board Schematic, #1 of 3

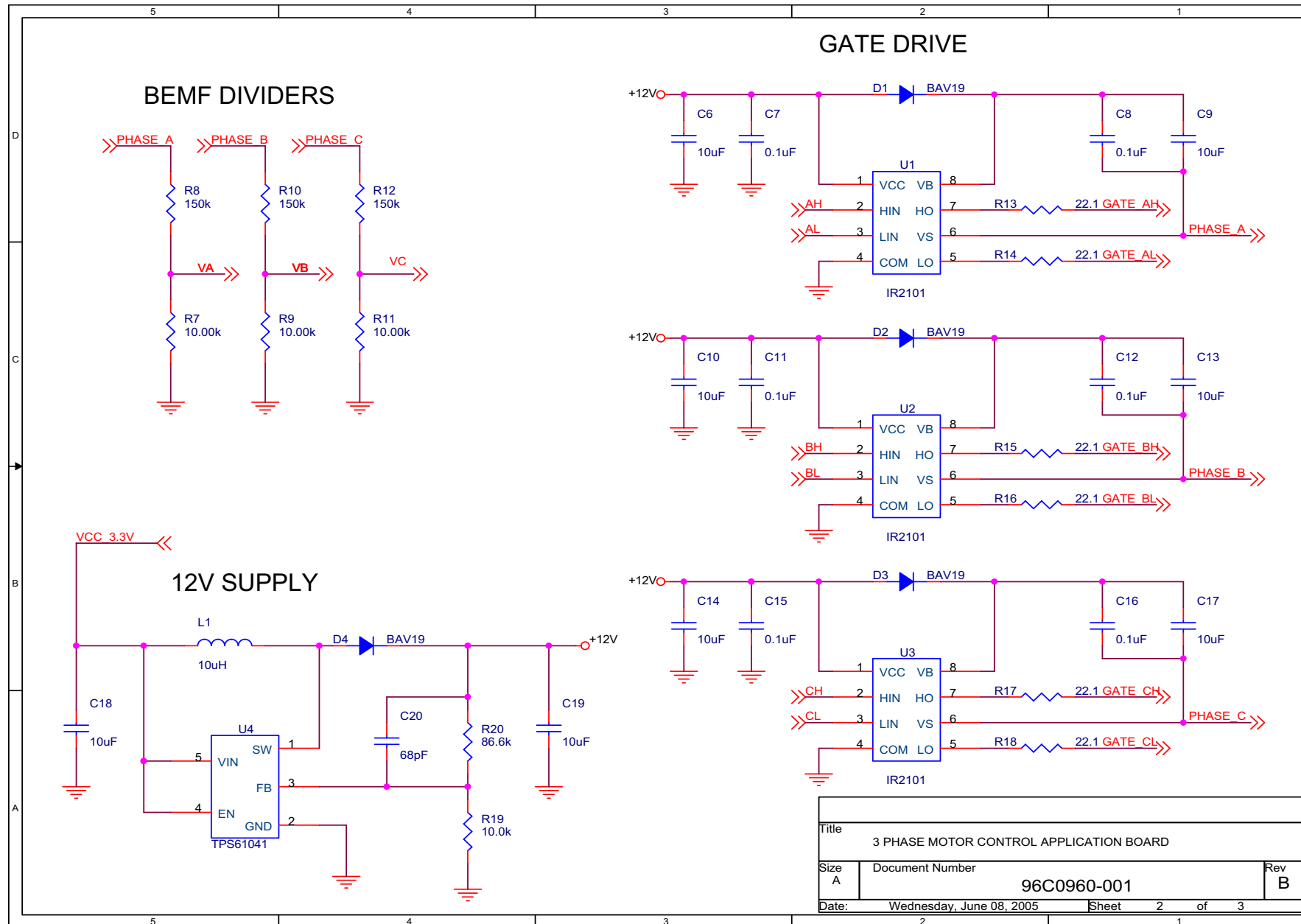

Figure 8. 3-Phase Motor Control Application Board Schematic, #2 of 3

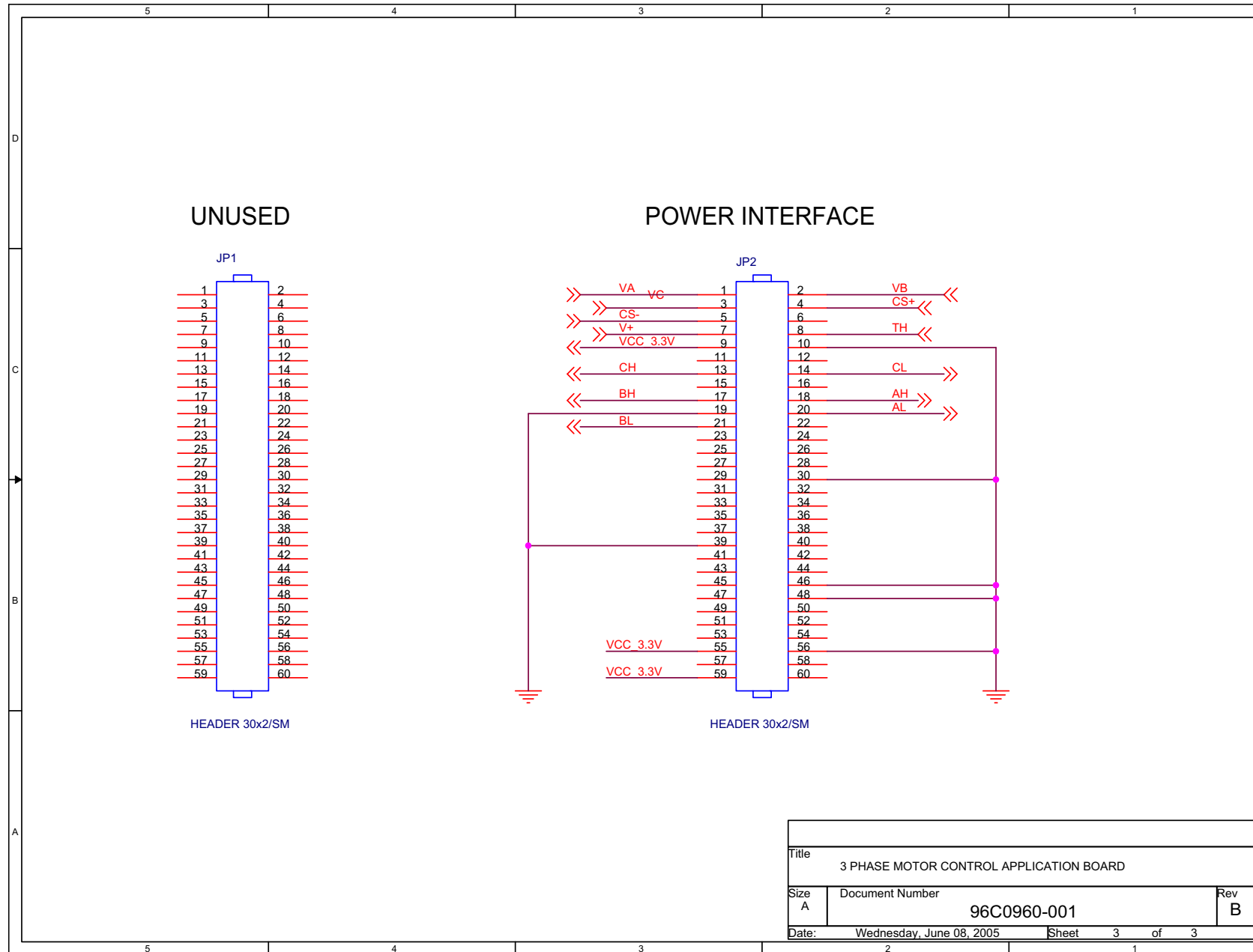
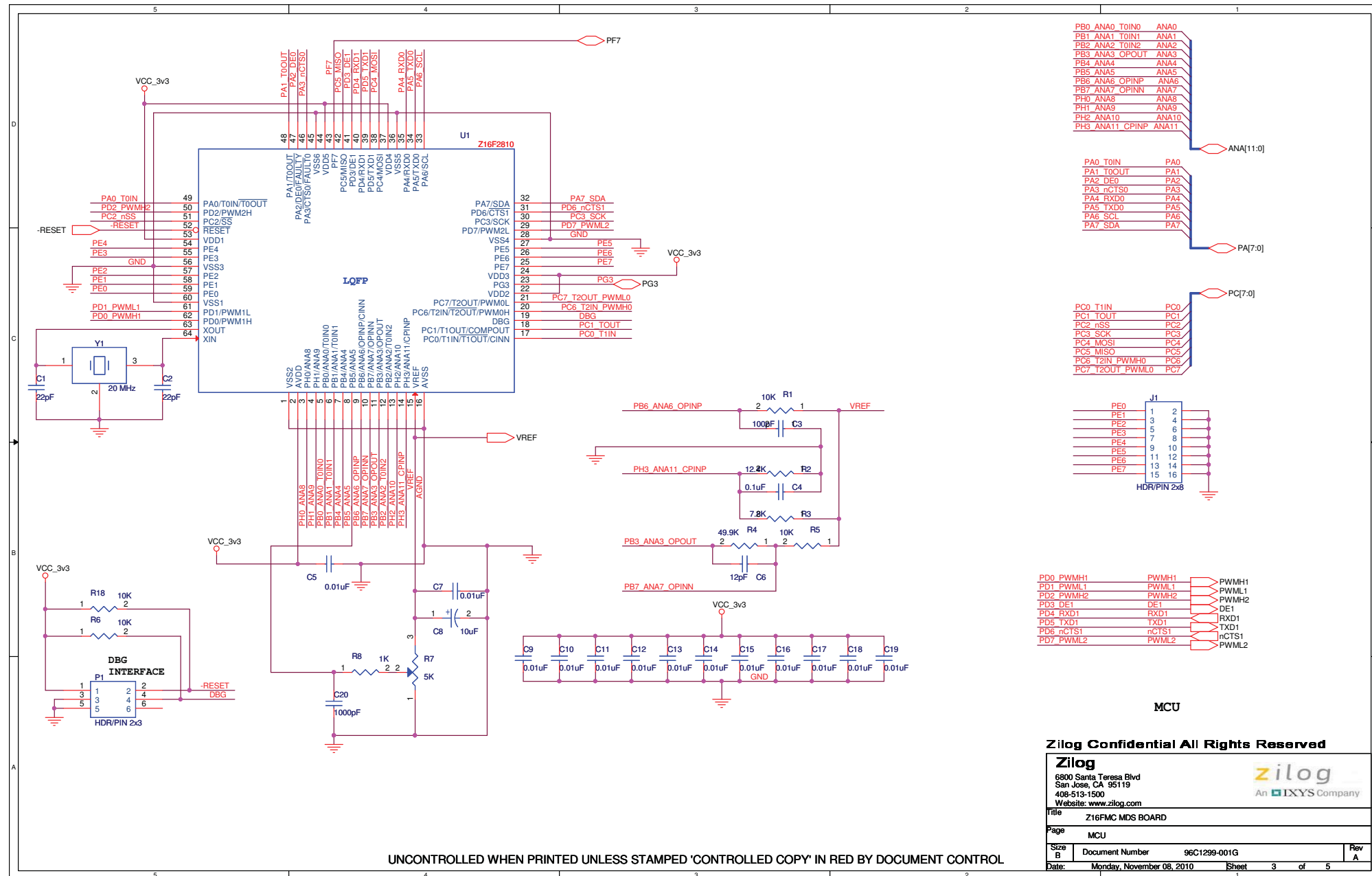

Figure 9. 3-Phase Motor Control Application Board Schematic, #3 of 3

Figures 8 through 10 display schematics of the MC MDS Board and Module.



UNCONTROLLED WHEN PRINTED UNLESS STAMPED 'CONTROLLED COPY' IN RED BY DOCUMENT CONTROL

Zilog Confidential All Rights Reserved

Zilog 6800 Santa Teresa Blvd San Jose, CA 95119 408-513-1500 Website: www.zilog.com		
Title: Z16FMC MDS BOARD		
Page: MCU		
Size: B	Document Number: 96C1299-001G	Rev: A
Date: Monday, November 08, 2010	Sheet: 3	of 5

Figure 8. Z16FMC MDS Board Schematic, #1 of 3

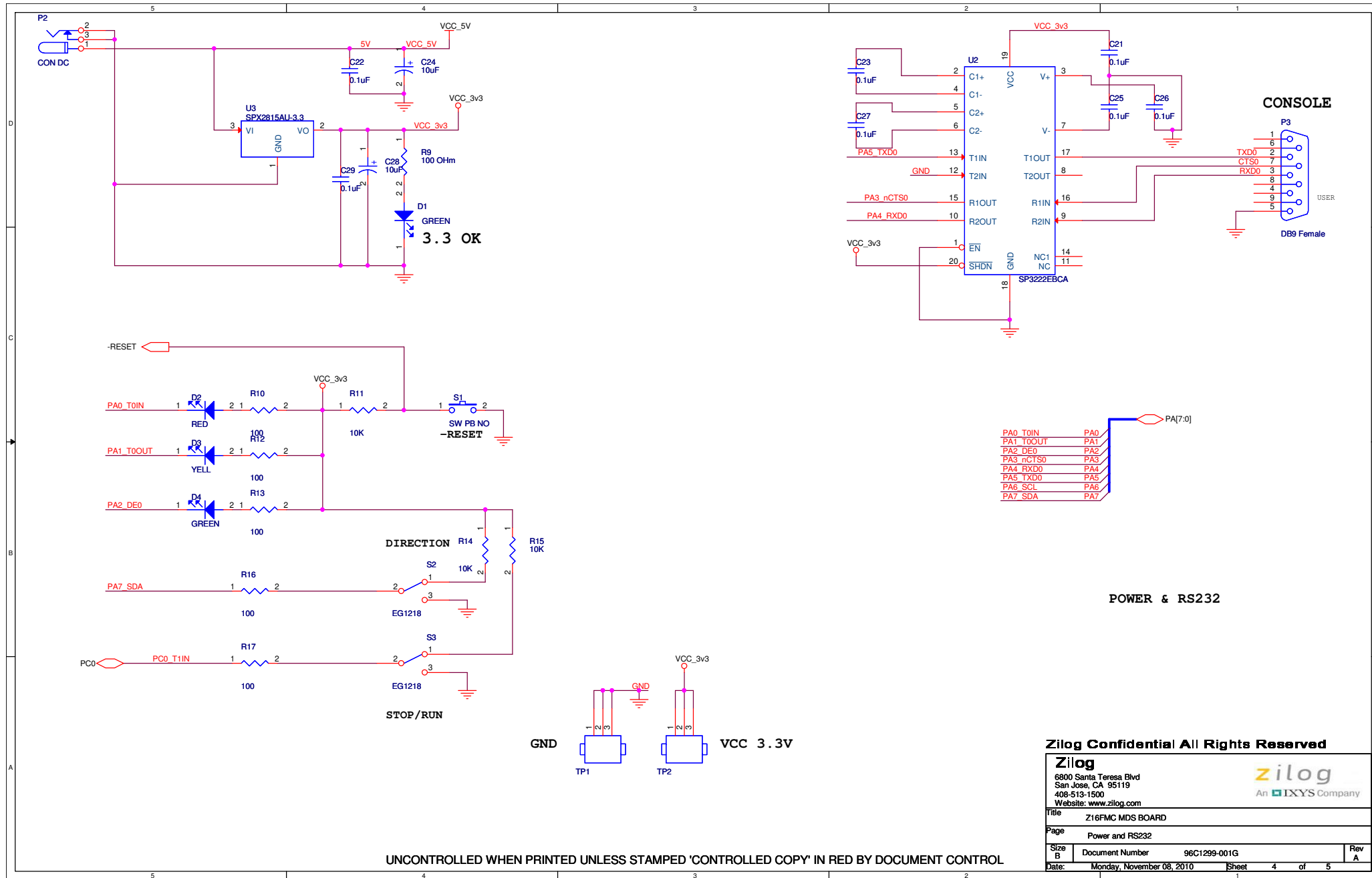
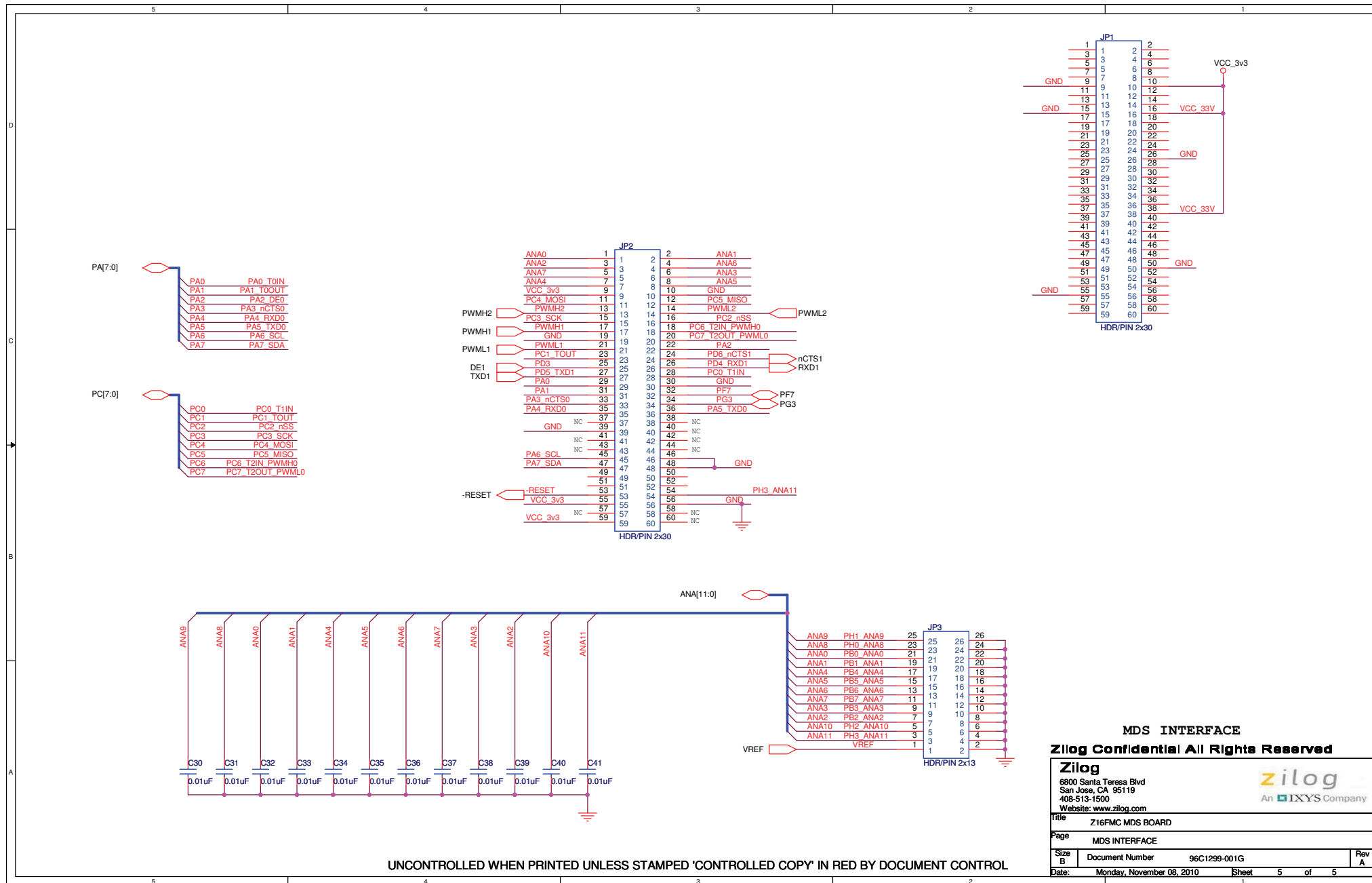

Figure 9. Z16FMC MDS Board Schematic, #2 of 3



MDS INTERFACE

Zilog Confidential All Rights Reserved

Zilog 6800 Santa Teresa Blvd San Jose, CA 95119 408-513-1500 Website: www.zilog.com		 An IXYS Company	
Title: Z16FMC MDS BOARD			
Page: MDS INTERFACE			
Size: B	Document Number: 96C1299-001G	Rev: A	
Date: Monday, November 08, 2010	Sheet: 5	of: 5	

Figure 10. Z16FMC MDS Board Schematic, #3 of 3