



An  IXYS Company

Application Note

Sensorless Brushless DC Motor Control with Z8 Encore! MC™ Microcontrollers



AN022602-0810

Abstract

This application note discusses the closed loop control of a 3-Phase Brushless Direct Current (BLDC) motor using the Z8 Encore! MC™ family of Microcontrollers (MCUs). The Z8 Encore! MC™ product family is designed specifically for motor control applications, featuring an on-chip integrated array of application-specific analog and digital modules. This in turn results in fast and precise fault control, high system efficiency, and on-the-fly speed/torque and direction control, as well as ease of firmware development for customized applications.

This article further discusses ways on how to implement a sensorless feedback control system using a Phase Locked Loop along with Back EMF sensing. Test results are based on using the Zilog BLDC Motor Control Development kit Z8FMC160100KITG. This development kit includes a Motor Control Motor Drive System module with a 32-pin Z8FMC16100 MCU, a 3-Phase Motor Control Application Board and a 3-phase 24-VDC, 30-W, 3200-RPM BLDC motor with Internal Hall Sensors.

► *Note: This application note was tested with version 4.11.0 of ZDS II. Subsequent releases of ZDS II might require you to modify code supplied with this application note.*

Features

The key features of this reference design include:

- Smooth S-curve motor start-up with reduced starting current
- Sensorless (Back-EMF) control using Phase Locked Loop feedback
- Microcontroller-based overcurrent protection
- Selectable Speed or Torque Setting
- Selectable Speed or Torque Control
- Selectable control of motor direction
- LED for max speed indication
- LED for motoring running indication
- LED for Fault indication

Discussion

The use of BLDC motors has steadily increased over the last several years as the cost of these motors and the technology to control these motors has decreased and the benefits of these motors over other motor types has become more important than just the initial cost. Variable speed motor applications in industries such as White Goods, Automotive, Aerospace, Medical, and Industrial Automation are now using the BLDC motor over other types of motors, such as Brushed DC and AC Induction.

The construction of a BLDC motor gives it several advantages when compared to other electric motors. First, since the BLDC uses electronic commutation it has a longer life when compared with brushed DC motors and requires less maintenance since the brushes on the motor do not require cleaning and replacement. They also run much quieter, both electrically and audibly, because the motor does not have brush arcing and the mechanical commutation of other types of motors. A BLDC motor will generally have a higher output per frame size since the windings are connected to the stator and the heat generated from running can be transferred directly to the motor housing allowing cooler operation. Finally, a BLDC motor will have much lower electrical and friction losses because they don't need to transfer power from the brushes. These losses are most prevalent at lower loads. The data has shown that a standard BLDC motor will have 5-10% better efficiency than typical AC induction motors and 8-12% better efficiency than brushed DC motors.

Multiple control methods exist for BLDC motor, and the selection is based on the requirements of the applications. The most cost effective is sensorless control. When using this method, the back EMF of the un-energized coil is used to determine the rotor position. However, when starting the motor, no back EMF is generated when the rotor is not in motion, so the motor can move in the wrong direction for a small period of time until the rotor position is determined. Sensorless control can be implemented with a few discrete components and a small amount of firmware, which make it very attractive from a cost standard point when some small initial movement of the motor is not a safety issue.

Theory of Operation

In a Brushless DC motor, the rotor uses permanent magnets, while the stator windings are similar to those in AC induction motors. For a detailed discussion of the BLDC motor fundamentals, as well as closed-loop control using sensorless techniques, refer to the *Motor Control Electronics Handbook* by Richard Valentine, McGraw-Hill, NY, 1998.

In a Brushed DC motor, commutation is controlled by brush position. In a BLDC motor, however, commutation is controlled by the supporting circuitry. The rotor's position must therefore be fed back to the supporting circuitry to enable proper commutation.

Two different techniques can be used to determine rotor position:

- **Hall Sensor-based commutation**—In the Hall sensor technique, three Hall sensors are placed inside the motor, spaced 120 degrees apart. Each Hall sensor provides either a High or Low output based on the polarity of magnetic pole close to it. Rotor position is determined by analyzing the outputs of all three Hall sensors. Based on the output from Hall sensors, the voltages to the motor's three phases are switched.

The advantage of Hall sensor-based commutation is that the control algorithm is simple and easy to understand. Hall sensor-based commutation can also be used to run the motor at very low speeds. The disadvantages are that its implementation requires both separate Hall sensors inside the motor housing and

additional hardware for sensor interface.

- **Sensorless commutation**—In the sensorless commutation technique, the back-EMF induced in the idle phase is used to determine the moment of commutation. When the induced idle-phase back-EMF equals one-half of the DC bus voltage, commutation is complete.

The advantage of sensorless commutation is that it makes the hardware design simpler. No sensors or associated interface circuitry are required. The disadvantages are that it requires a relatively complex control algorithm, and, when the magnitude of induced back-EMF is low, it does not support low motor speeds.

Furthermore, two voltage application techniques can be applied, based on the configuration of the supply-to-motor windings:

- **Sinusoidal**—Sinusoidal voltage is applied to the three-phase winding. Sinusoidal voltage provides a smooth motor rotation and fewer ripples.
- **Trapezoidal**—Here DC is applied to two phases at a time, and the third phase is left idle. Trapezoidal voltage is simpler to implement and less complex.

In this application, sensorless control with a trapezoidal waveform is implemented. This implementation is very common in small BLDC motors used in many White Goods and other consumer-based products.

The block diagram of the BLDC motor control system is shown in [Figure 1](#) on page 4 and is based on Z8FMC16100. In a 3-Phase commutation arrangement, at any given instance, only two phases are energized. The back EMF voltage is in turn generated in the unenergized phase winding, and the zero crossing of this induced voltage is detected for synchronization of the subsequent closed-loop control events. As discussed later, the innovative Time Stamp feature of the Z8FMC16100 MCU provides for robust, efficient implementation of this critical sensing function without the requirement for an additional comparator.

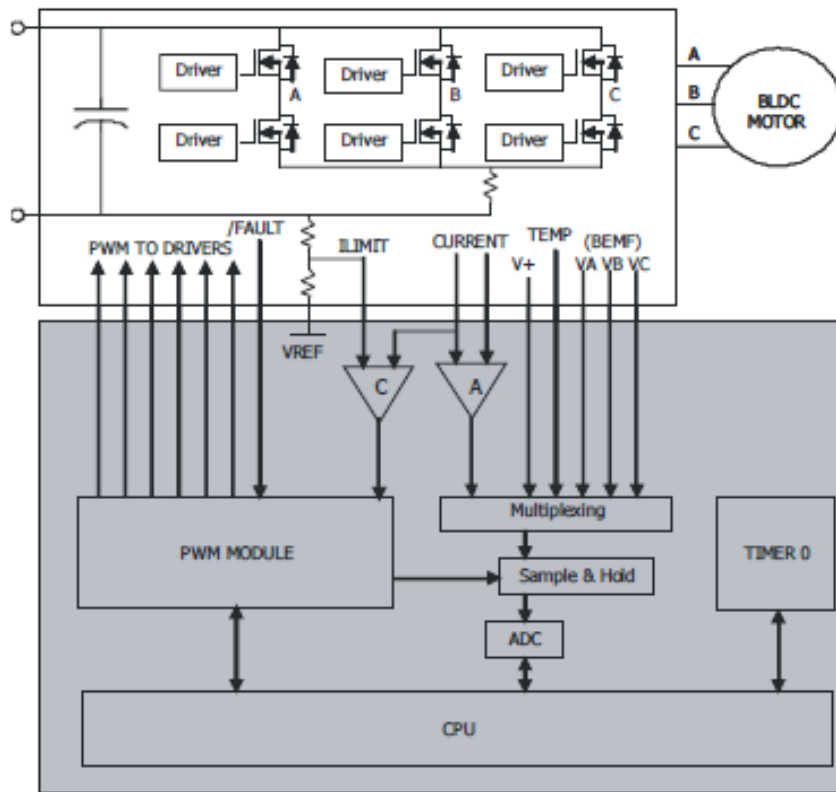

Figure 1. Three-Phase Motor Control System

The algorithm for Back EMF sensing is based on the implementation of a Phase Locked Loop (PLL). This is especially advantageous during startup, resulting in a gradual increase in the motor speed as well as nearly instantaneous reversal of direction of rotation on command, as outlined below.

In the conventional approach, during the startup sequence, power is applied to the windings in order to place the rotor in a known starting position, followed by commutation and start of Back EMF sensing and control. In contrast, the PLL-based approach implemented herein makes possible locking to the Back EMF signal from the very onset of startup phase, without the need for the initial placement of the rotor in a specific position. Moreover, this approach significantly reduces the erratic movement of the motor during startup or reversal of direction.

Following the startup phase, during the normal operation phase, torque/current mode control is achieved via sensing of the voltage generated across a sense resistor in the motor drive circuit. This voltage is routed to the on-chip integrated ADC, after which data processing by the CPU based on a predefined computational algorithm results in the regulation of the Pulse Width Modulation (PWM) commutation signal period.

Another key feature of the Z8FMC16100 MCU is the direct coupling of the on-chip integrated comparator to the PWM module, enabling fast, cycle-by-cycle shutdown during an overcurrent fault event.

In conjunction with the integrated on-chip hardware blocks, the 3-phase BLDC motor control software developed herein allows for ease of programming to achieve the desired closed-loop control characteristics. The routines that enable the sensing of the motor's Back EMF and current are all interrupt driven. It is critical

that the highest interrupt priority is assigned to the Back EMF sensing event, as this is a critical step for subsequent synchronization of the commutation events. In this case, Timer 0 is used for the Time Stamp function as well as for updating the commutation period if necessary.

Hardware Architecture

Figure 1 on page 4 displays the functional block diagram of the Z8 Encore! MC™ Sensorless Brushless Motor Controller. This block diagram can be divided into the Control Section and the Power Conversion section.

In the Control Section, the Z8FMC16100 MCU is operating with an external 20-Mhz crystal. Table 1 provides a list of pins being used in the Z8FMC16100 MCU along with the associated use in this design.

Table 1. Pin Function Descriptions

Pin No.	Pin Description	Function	In/Out/PWR	Application Use
1	PB2/ANA2/TOIN2	ANA2	Input	Phase C BEMF
2	PB1/ANA1/TOIN1	ANA1	Input	Phase B BEMF
3	PB0/ANA0/TOIN0	ANA0	Input	Phase A BEMF
4	AVVD	AVVD	PWR	3.3V Supply
5	AVVS	AVVS	PWR	Ground
6	VREF	VREF	PWR	Voltage Reference
7	PA0/OPINN	OPINN	Input	Current Sense
8	PA1/OPINP/CINN	OPINP	Input	Current Sense
9	PA2/CINP	CINP	Input	Current Sense
10	PA7/FAULT1/T0OUT...	PA7	Output	Fault(Red) LED
11	RESET/FAULT0	RESET	Input	STOP/RESET
12	DBG	DBG	Input/Output	DEBUG
13	PC0/T0OUT	PC0	Input	Direction
14	PWML2	PWML2	Output	Phase C Gate Low
15	PWMH2	PWMH2	Output	Phase C Gate High
16	PWML1	PWML1	Output	Phase B Gate Low
17	PWMH1	PWMH1	Output	Phase B Gate High
18	PWML0	PWML0	Output	Phase A Gate Low
19	PWMH0	PWMH0	Output	Phase A Gate High
20	VSS	VSS	PWR	Ground
21	XOUT	XOUT	Output	Clock
22	XIN	XIN	Input	Clock
23	VDD	VDD	PWR	3.3V Supply
24	PA3/TXDE/SCK/SCL	PA3	Output	Power(Yellow) LED
25	PA4/RXD/MISO	RXD	Input	UART Receive
26	PA5/TXD/MOSI	TXD	Output	UART Transmit
27	PA6/CTS/SS/SDA	CTS	Input	UART Clear
28	PB7/ANA7	PB7	Output	Run(Green) LED
29	PB6/ANA6	ANA6	Input	Speed
30	PB5/ANA5	ANA5	Output	ISR Test Pin
31	PB4/ANA4/CINN	ANA4	Input	DC Bus Voltage
32	PB3/ANA3/OPOUT	ANA3	Input	Current Sense

The Power Conversion section contains the DC Bus, Gate Drivers, MOSFETs, Power Supply, BEMF dividers, and temperature sensor. The MOSFETs used in this design are IXYS high-efficient trench gate power technology. To control the small 30-W BLDC motor, part number IXTP64N055T was selected. However, this design is scalable to meet the needs of the majority of 3-Phase BLDC motors from 1 W to 5 kW. To support larger motors, the major design changes are in the Power Conversion section, which include the fuse and the MOSFETs. The IXYS family of power MOSFETs, which includes both discrete and modules, come in a wide variety of packages in order to meet the specific mechanical requirements of the application. They also come in a wide range of power ratings and can support in excess of 500 A.

Software Architecture

The Z8 Encore! MC™ family of Microcontrollers has up to 16 KB of FLASH memory and is based on Zilog's advanced eZ8 8-bit CPU core, providing for closed loop control of single- and multiphase variable speed motors. Target applications are major appliances, HVAC, industrial automation, and consumer electronics. In each of the Z8 Encore! MC™ products, the novel device architecture allows for the realization of a number of enhanced control features including Time Stamp for Speed Control, Integrated Operational Amplifier, and Fault Response.

Time Stamp for Speed Control

Most microcontrollers use at least one dedicated comparator to detect the zero crossing of the input AC voltage signal, so that the output driving pulses can be synchronized and adjusted to properly regulate the motor speed. An alternative approach based on Zilog's motor control MCU eliminates the need for this comparator by instead employing an ADC in conjunction with a timer. In this case, the ADC samples the AC line voltage, with the timer running in the background.

After the ADC samples the line voltage zero crossing, the timer count is read, and the result is written to a register. This in turn cues the timers for the output PWM pulses to efficiently regulate the speed of the motor. The Time Stamp approach results in a very simple and cost-effective solution for the smooth operation of the motor in steady state.

Integrated Operational Amplifier

Motor controllers almost invariably monitor motor speed by sensing the current through the windings, using sensor and sensorless techniques in conjunction with the ADC. Ordinarily, sampling instances by the ADC are synchronized by the MCU.

In this process, an operational amplifier is used to convert the current signal to a voltage signal, respectively. The ADC in turn samples the voltage signal and outputs the result to the processor. The processor will then synthesize the PWM outputs to control motor speed.

In the case of the Z8 Encore! MC™ family of Microcontrollers, an on-chip integrated operational amplifier eliminates the need for an external component, hence reducing the overall system cost.

Fault Response

Overcurrent faults can result from many different causes and are sometimes destructive. Shorted motor windings, shorted motor leads, problems in mechanical drives and linkages, a stuck rotor or changes in the

load, breakdowns or misfiring of power devices, and many other problems can arise, some of them permanent, some merely temporary. Whatever may be the origin of an overcurrent condition, motor rotation must be halted. In this scenario, fast response time is a key criteria for the design of the fault protection system. However, rather than triggering a hard shutdown of the entire system when a fault is detected, it is better to disable the motor drive outputs on a cycle-by-cycle basis, with normal operation resuming once the fault condition is no longer detected. In this case, if the overcurrent condition persists, a hard shutdown then ensues.

Motor control microcontrollers typically incorporate input elements (such as a comparator) for sensing overcurrent conditions. In many cases, the current signal is routed to the ADC. This approach has a major drawback due to the excess time associated with data processing before the outcome can disable the PWM. The resulting data processing latency could in turn delay system shutdown beyond the next switching cycle, and catastrophic damage could result.

In the Z8 Encore! MC™ family of Microcontrollers, in order to avoid the processing delay inherent with an ADC, an overcurrent comparator is directly coupled to the PWM module, thereby guaranteeing that the shutdown can truly occur in a cycle-by-cycle mode. This approach not only improves the controller's fault response characteristics, but also circumvents a vulnerability that is inherent with the conventional approach. Namely, if the MCUs clock were to stop functioning, there would be no risk of accomplishing a shutdown in response to an overcurrent fault as there would be if the system's ADC were involved.

All the algorithms have been developed in C using the Zilog ZDS II Integrated Development Environment for the Z8 Encore!® family of products. [Figure 2](#) shows the main control loop.

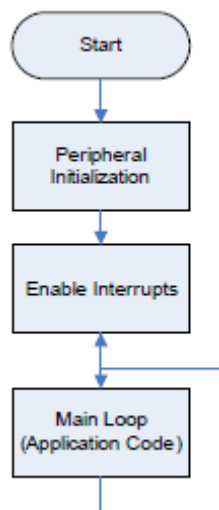

Figure 2. Initialization and Application Code Space

This implementation provides precise control of the motor while leaving sufficient resources for additional application code. Even when using a very small and cost-effective 8-bit MCU, an additional 13 KB of Flash and 420 bytes of RAM are available for additional user application code.

The Phase Lock Loop Back EMF sensing is unique to this implementation. The details of the algorithm are described in the following figures and tables. The Back EMF sensing loop is shown in [Figure 3](#) on page 8.

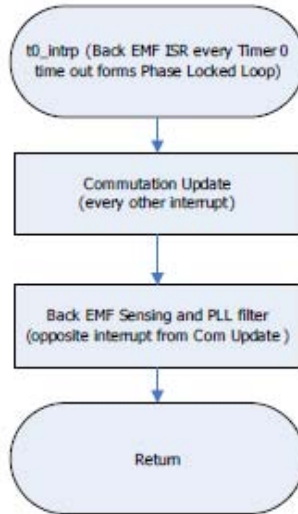

Figure 3. Back EMF Sensing Phase Locked Loop

The Phase Locked Loop Back EMF algorithm that has been implemented to provide a smooth startup of the motor is shown in Figure 4 and Figure 5 (page 9). Additional details on the specific formulas used are shown in Table 2 on page 10.

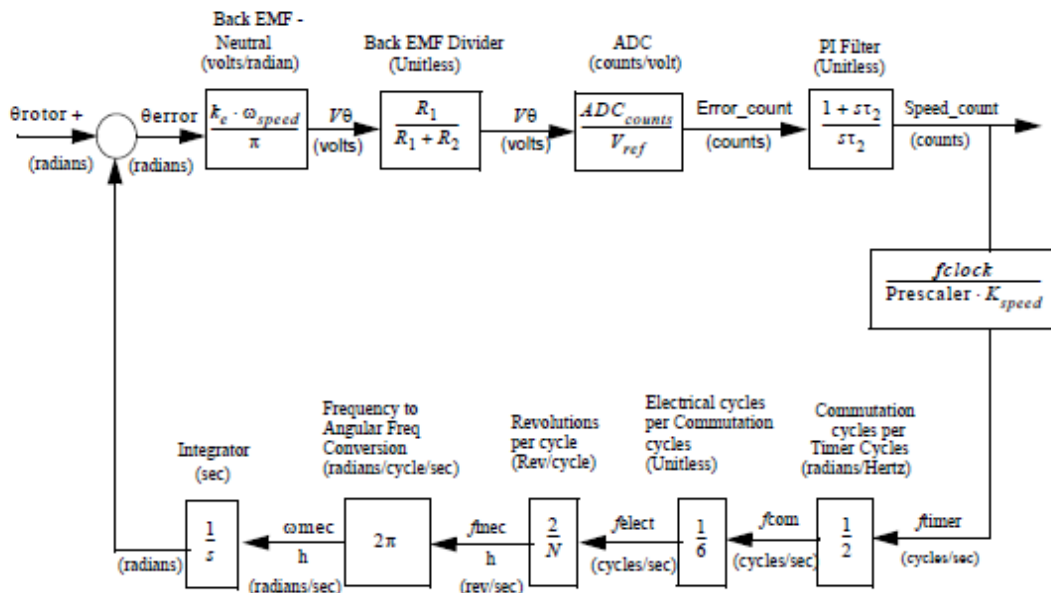

Figure 4. Back EMF Sensing Phase Locked Loop

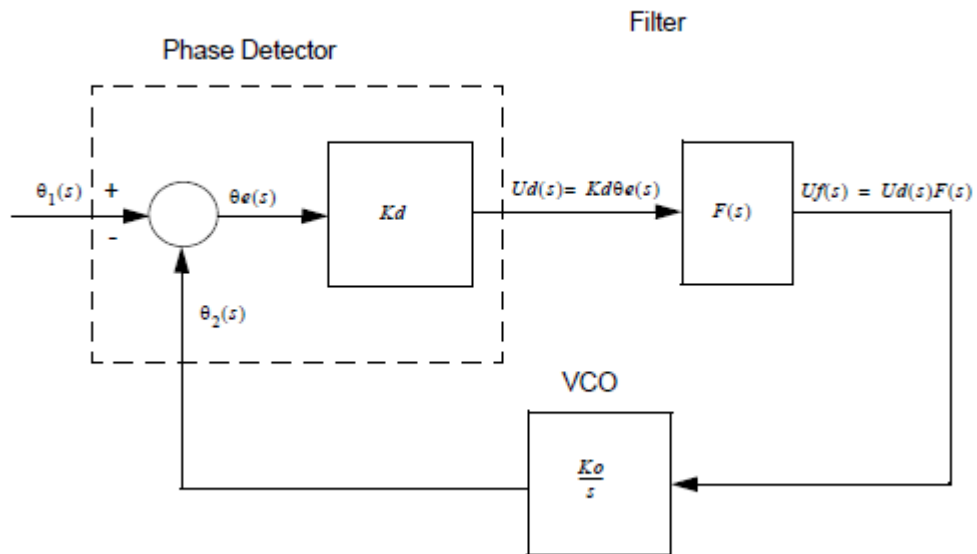

Figure 5. Proportional Integral (PI) Filter Representation for Back EMF Sensing

Table 2. Back EMF Sensing Phase Locked Loop

$D = \frac{R_1}{R_1 + R_2}$	Divider Ratio
$K_d = \frac{K_e \cdot \omega_{speed} \cdot D}{2\pi}$	(volts/rad) ω_{speed} = current speed of motor
$F(s) = \frac{1 + s\tau_2}{s\tau_1}$	τ_1 = numeric constant τ_2 = numeric constant
$K_o = \frac{ADC_{counts} \cdot f_{clock} \cdot 2 \cdot 2\pi}{V_{ref} \cdot Prescaler \cdot 6 \cdot N \cdot K_{speed}}$	(rad/sec/volt)
$K_{speed} = \frac{(2 \cdot 2\pi \cdot f_{clock} \cdot speed_count_max)}{(2 \cdot 6 \cdot N \cdot \omega_{max} \cdot Prescaler)}$	Speed_count_max = counts at max speed ω_{max} = Maximum motor speed (rad/sec)
$K_o = \frac{ADC_{counts} \cdot \omega_{max}}{V_{ref} \cdot speed_count_max}$	(rad/sec/volt)
$\omega_n = \sqrt{K_d \cdot K_o \cdot \tau_1} = \omega_{max}$	Natural frequency
$\zeta = \frac{\omega_n \cdot \tau_2}{2} = 0.707$	Damping factor
$H(s) = \frac{\theta_2(s)}{\theta_1(s)} = \frac{2 \cdot s \cdot \zeta \cdot \omega_n + \omega_n^2}{s^2 + 2 \cdot s \cdot \zeta \cdot \omega_n + \omega_n^2}$ $A_{ol}(s) = K_d \cdot F(s) \cdot \frac{K_o}{s} = K_d \cdot K_o \cdot \frac{1 + s\tau_2}{s^2\tau_1}$	Closed Loop Transfer Function
$A_{ol}(s) = \frac{s \cdot K_d \cdot K_o \cdot \tau_2 + K_d + K_o}{s^2\tau_1}$	Open Loop Gain

Starting with the transfer function of the Proportional Integral (PI) Filter in the s-plane

$$F(s) = \frac{Y(s)}{R(s)} = \frac{1 + s\tau_2}{s\tau_1}$$

$$s = \frac{2}{T} \frac{z-1}{z+1}$$

Using the bilinear z-transform identity where T = the sampling period

$$F(z) = \frac{Y(z)}{R(z)} = \frac{1 + \left(\frac{2z-1}{Tz+1}\right)\tau_2}{\left(\frac{2z-1}{Tz+1}\right)\tau_1} \quad \text{Multiply by } Tz - T$$

$$F(z) = \frac{Y(z)}{R(z)} = \frac{Tz + T + (2\tau_2)(z - 2\tau_2)}{(2\tau_1)z - 2\tau_1}$$

$$zY(z) - Y(z) = \left(\frac{T + 2\tau_2}{2\tau_1}\right)zR(z) + \left(\frac{T - 2\tau_2}{2\tau_1}\right)R(z)$$

$$zY(z) - Y(z) = a_0zR(z) + a_1R(z)$$

where

$$a_0 = \frac{T + 2\tau_2}{2\tau_1} \quad a_1 = \frac{T - 2\tau_2}{2\tau_1}$$

$$Y(z) = z^{-1}Y(z) + a_0R(z) + a_1z^{-1}R(z) \quad \text{Collecting Terms and dividing by } z$$

Transforming back into the time domain

$$y(n) = y(n-1) + a_0r(n) + a_1r(n-1)$$

Writing out as Computer Program Variables this takes the form of a recursive filter with the coefficients A0 and A1.

$$Y0 = Y1 + A0 * R0 - A1 * R1$$

Where:

Y0 = current output

Y1 = output ant last sample period

R0 = current ADC sample of back EMF (phase voltage – vbus/2)

R1 = last sample of Back EMF from ADC

A0 = a0

A1 = -a1

The block diagram of the PWM loop is shown in [Figure 6](#) and can also be used for specific application code such as communications or additional user interfaces.

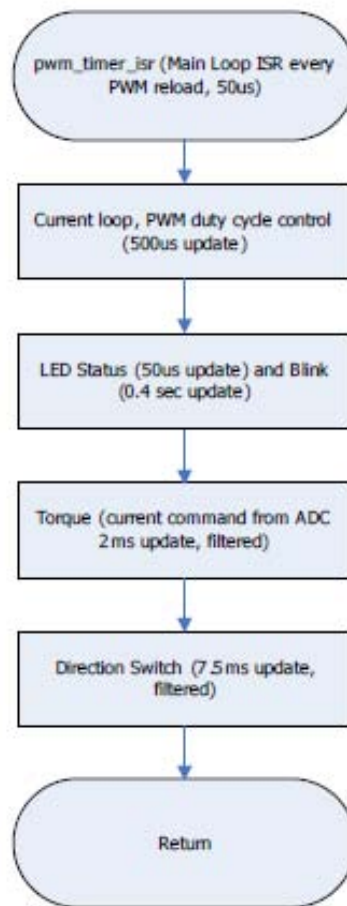

Figure 6. Current Loop and Timed Housekeeping

Testing

The Phase Locked Loop Back EMF algorithm is critical to a smooth startup and operation. Precise control of the PWM is required to create constant waveforms to the motor, resulting in the quiet operation of the motor. These waveforms are shown in [Figure 7](#), which captures the voltage on the gate for the High and Low side MOSFETs on Phase A while the motor is running with 24-VDC input and at the highest speed setting.

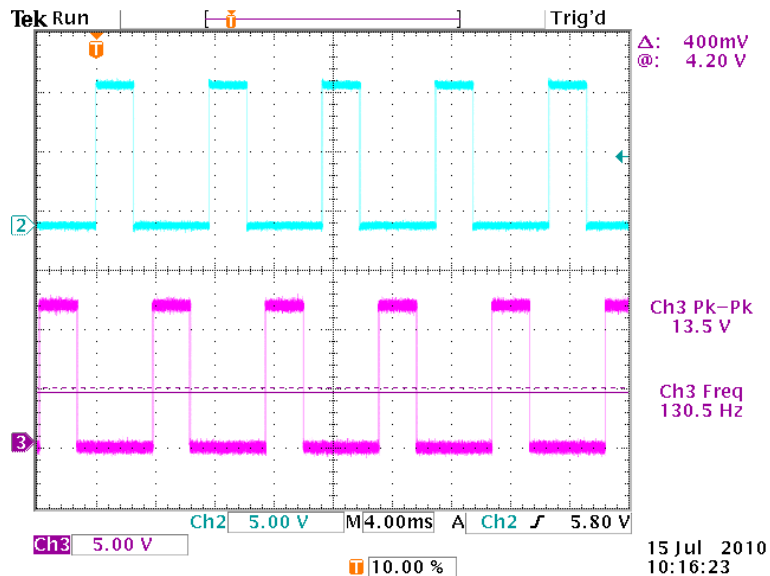

Figure 7. MOSFET Gate Signal

To verify the fast shutdown capability during an overcurrent event, the application was set up with an oscilloscope tied to the PWM output and the current sense resistor. The load was then connected to the BLDC Motor Control development kit and set up to gradually increase to an overcurrent state. The resulting oscilloscope-generated waveforms representing this sequence of events are shown in [Figure 8](#) on page 14.

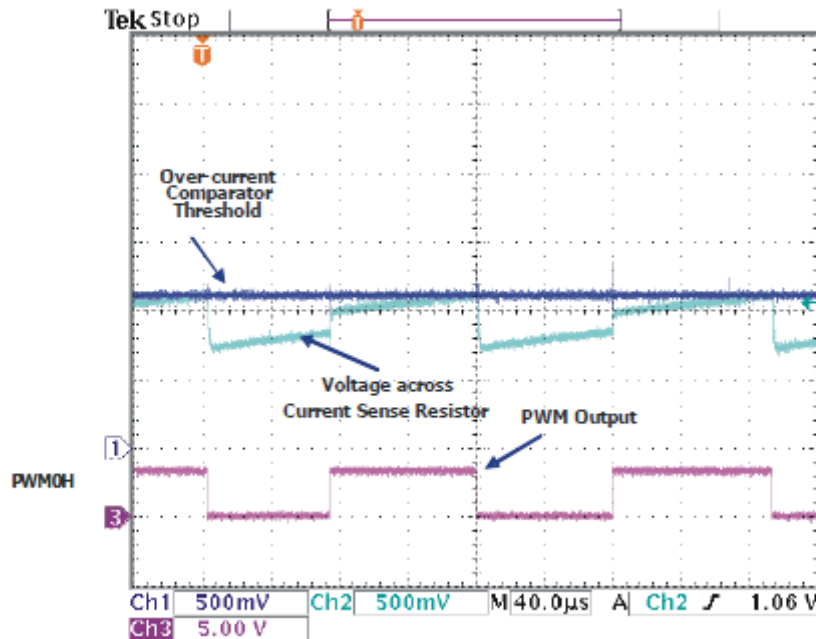

Figure 8. Cycle-by-Cycle Shutdown

Summary

This application note described the closed loop control of a sensorless BLDC motor using the advanced on-chip integrated features of the Z8 Encore! MC™ family of Microcontrollers. The Z8 Encore! MC™ product line is ideally suited for such applications, providing for a “seamless” startup of the motor from the idle mode to full operational speed, on-the-fly reversal of the direction of rotation, extremely fast fault detection cycle, and lower cost of the total solution. These features, along with the powerful eZ8 CPU core and some of the best development tools available in the industry, result in less complex board designs and reduced design cycle time.

References

The documents associated with Z8 Encore! MC™ Microcontrollers on www.zilog.com are listed below:

- BLDC Motor Control Using the Z8FMC16100 Application Brief (AB0005)
- Electric Bike BLDC Hub Motor Control Using the Z8FMC16100 MCU Application Note (AN0260)
- Z8 Encore! MC Flash Microcontrollers Z8FMC16100 Series Product Brief (PB0166)
- Z8 Encore! Motor Control Flash MCUs Z8FMC16100 Series Product Specification (PS0246)
- Z8 Encore! MC Z8FMC16100 Series Motor Control Development Kit Quick Start Guide (QS0054)
- Z8 Encore! MC Z8FMC16100 Series Motor Control Development Kit User Manual (UM0192)
- Z8 Encore! MC Z8FMC16100 Series In-Circuit Emulator and Development Tool (UM0190)
- Z8FMC16100 Series Motor Control Library Quick Start Guide (QS0056)
- Z8FMC16100 Series Motor Control Library Reference Manual (RM0046)
- Z8FMC16100 Series of Flash MCUs Motor Control Library User Manual (UM0199)

Appendix A—Schematics

Figure 9, Figure 10 (page 16), and Figure 11 (page 17) show the schematics for the 3-Phase Motor Control Application Board.

3 PHASE POWER STAGE

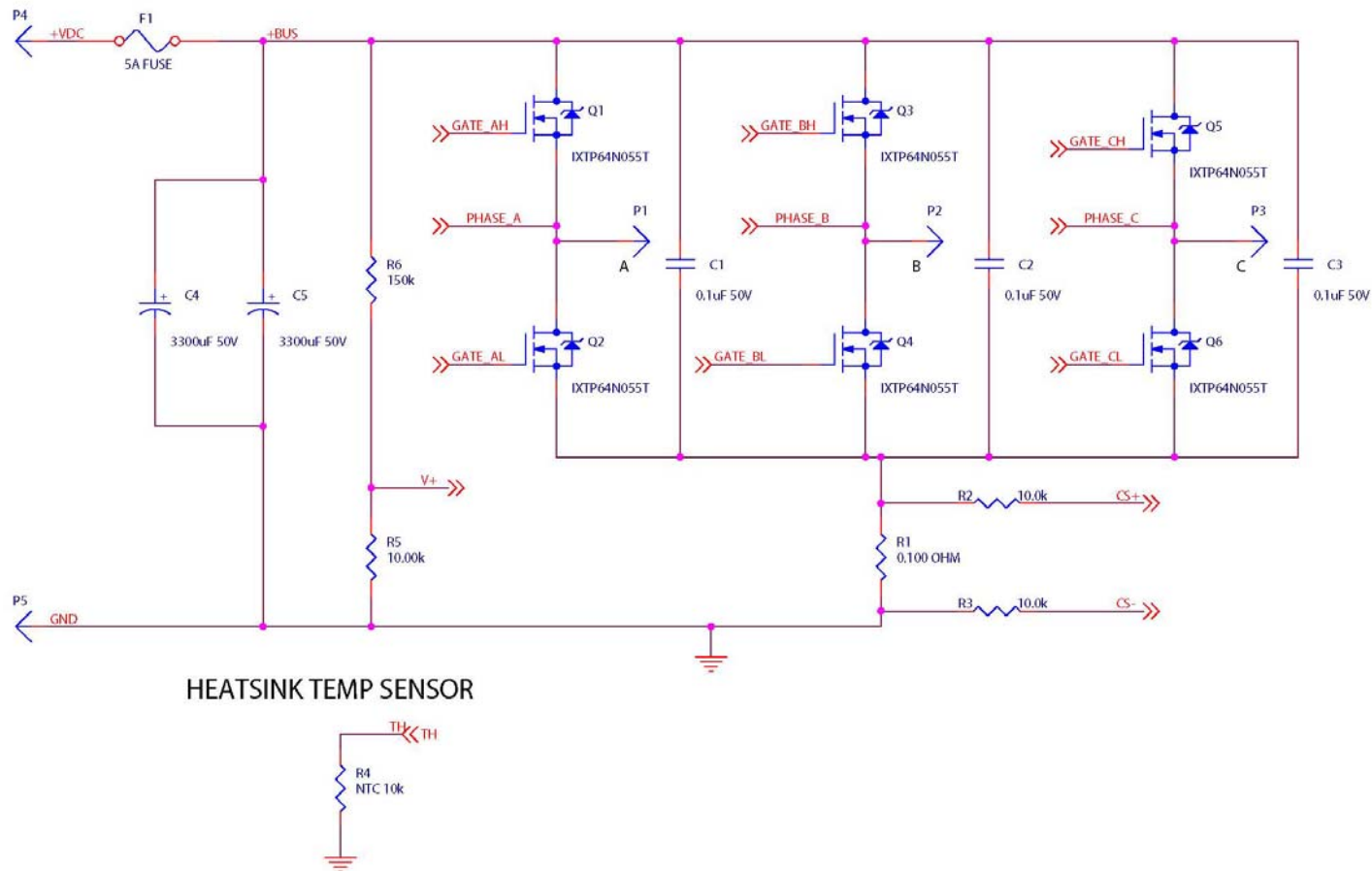

Figure 9. 3-Phase Motor Control Application Board (Part 1 of 3)

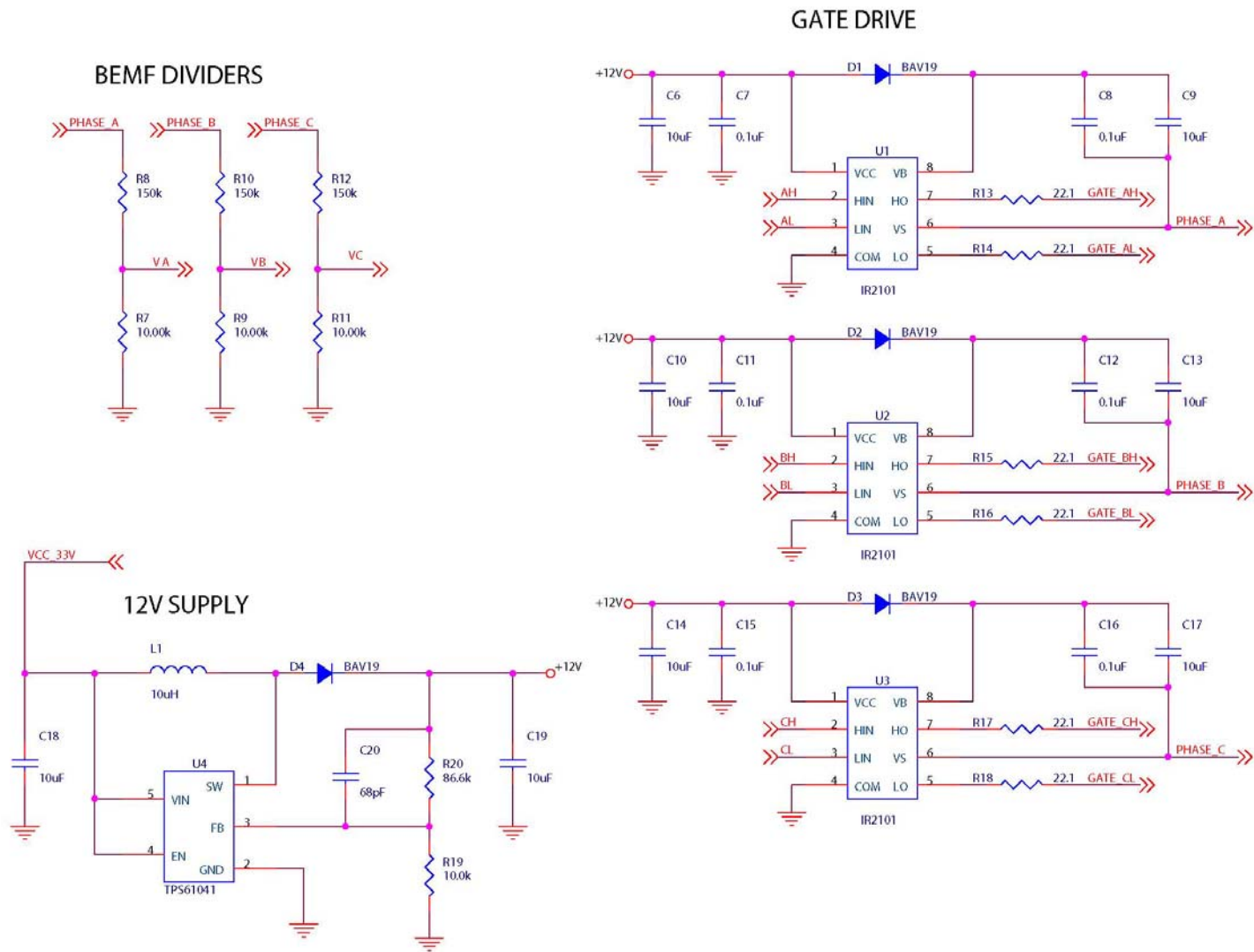
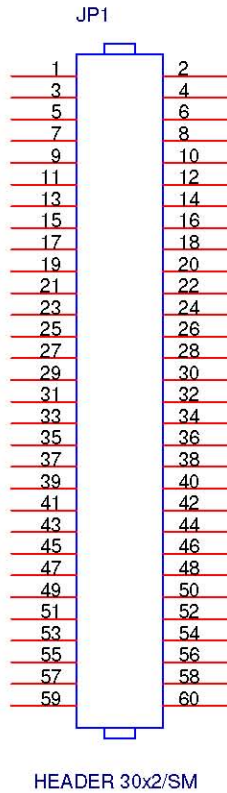

Figure 10. 3-Phase MotorControl Application Board (Part 2 of 3)

UNUSED



POWER INTERFACE

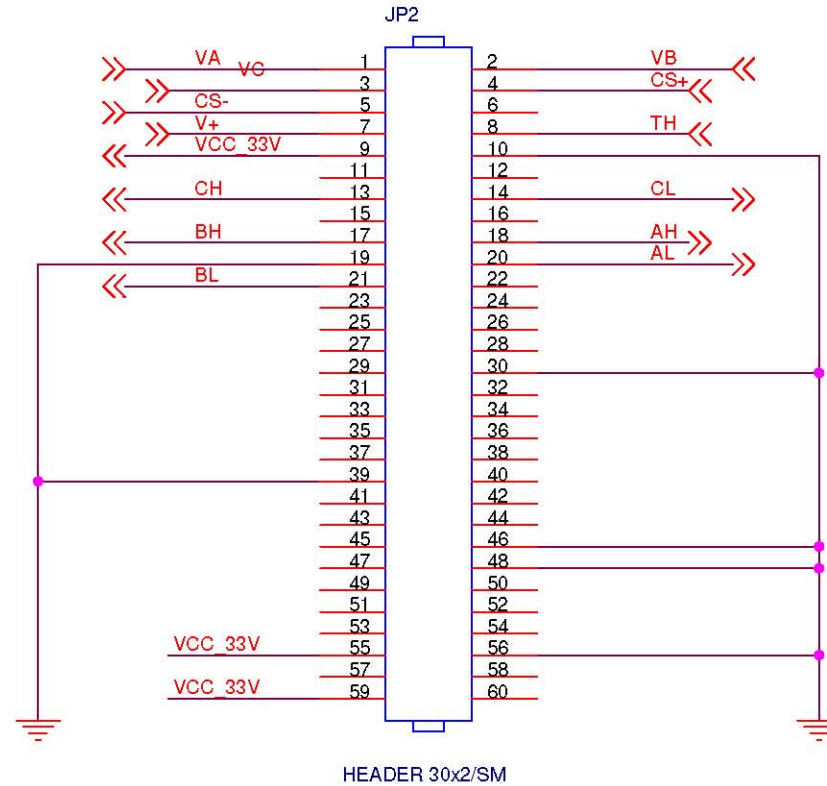

Figure 11. 3-Phase MotorControl Application Board (Part 3 of 3)

Figure 12 and Figure 13 (page 19) shows the schematic for the Motor Control MDS Module.

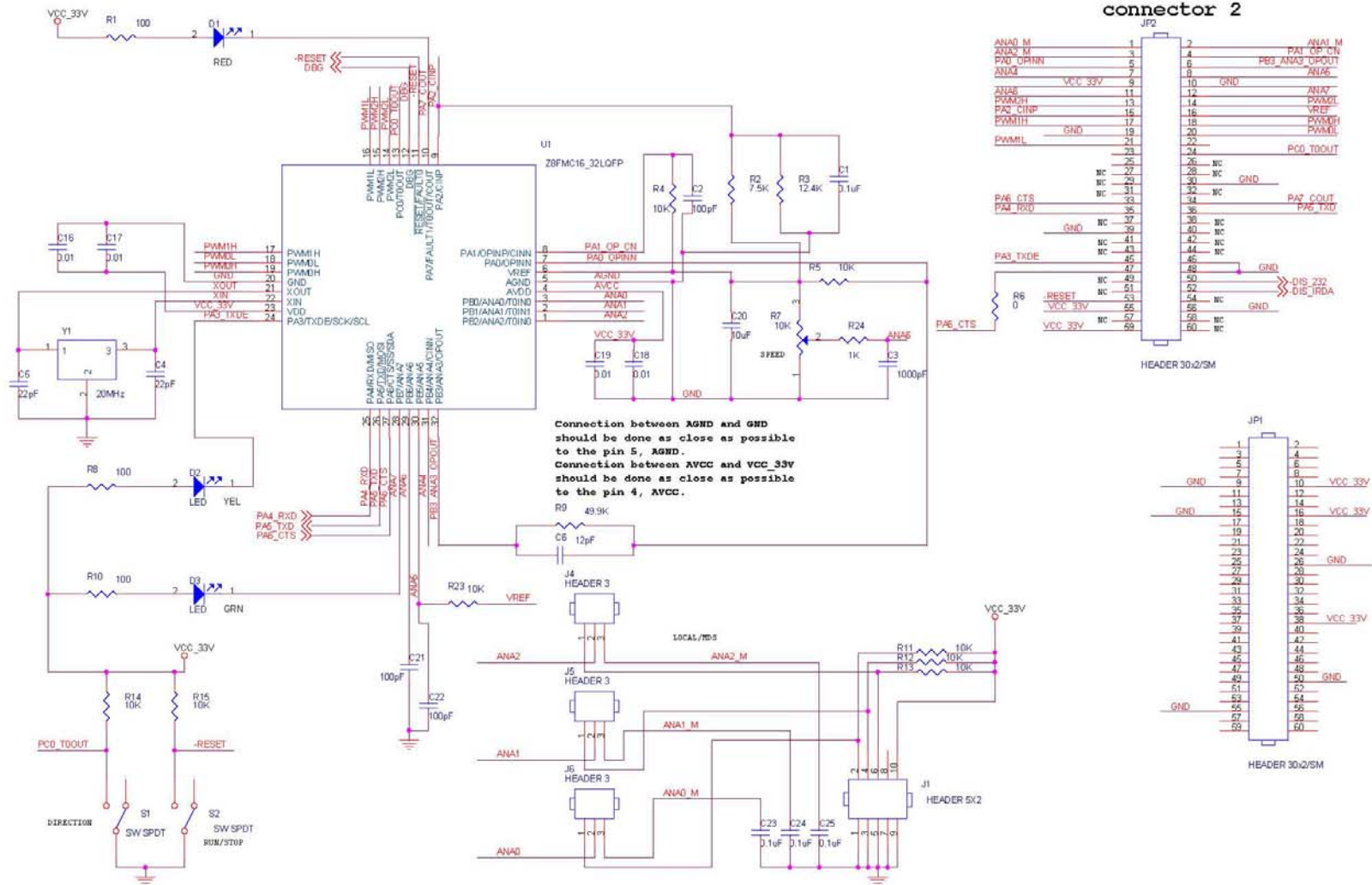

Figure 12. Z8FMC16 and MDS Connectors

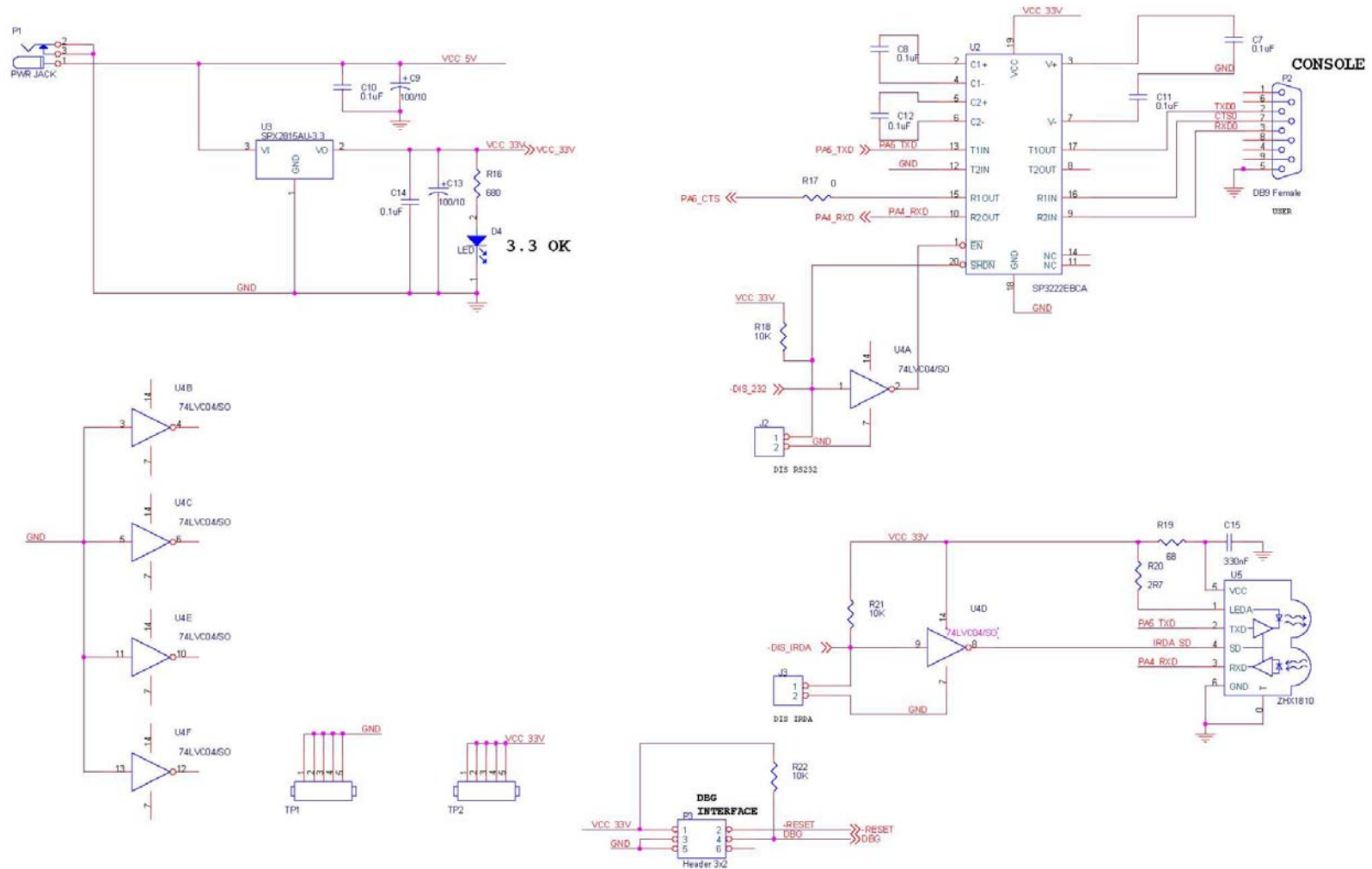

Figure 13. Z8FMC16 MDS Module (Power and Communications)



Warning: DO NOT USE IN LIFE SUPPORT

LIFE SUPPORT POLICY

ZILOG'S PRODUCTS ARE NOT AUTHORIZED FOR USE AS CRITICAL COMPONENTS IN LIFE SUPPORT DEVICES OR SYSTEMS WITHOUT THE EXPRESS PRIOR WRITTEN APPROVAL OF THE PRESIDENT AND GENERAL COUNSEL OF ZILOG CORPORATION.

As used herein

Life support devices or systems are devices which (a) are intended for surgical implant into the body, or (b) support or sustain life and whose failure to perform when properly used in accordance with instructions for use provided in the labeling can be reasonably expected to result in a significant injury to the user. A critical component is any component in a life support device or system whose failure to perform can be reasonably expected to cause the failure of the life support device or system or to affect its safety or effectiveness.

Document Disclaimer

©2010 by Zilog, Inc. All rights reserved. Information in this publication concerning the devices, applications, or technology described is intended to suggest possible uses and may be superseded. ZILOG, INC. DOES NOT ASSUME LIABILITY FOR OR PROVIDE A REPRESENTATION OF ACCURACY OF THE INFORMATION, DEVICES, OR TECHNOLOGY DESCRIBED IN THIS DOCUMENT. ZILOG ALSO DOES NOT ASSUME LIABILITY FOR INTELLECTUAL PROPERTY INFRINGEMENT RELATED IN ANY MANNER TO USE OF INFORMATION, DEVICES, OR TECHNOLOGY DESCRIBED HEREIN OR OTHERWISE. The information contained within this document has been verified according to the general principles of electrical and mechanical engineering.

Z8 Encore! MC is a trademark and Z8 Encore! is a registered trademark of Zilog, Inc. All other product or service names are the property of their respective owners.