

# Intelligent Power Management Solutions

Z8 Encore!<sup>®</sup> 8-Bit Microcontrollers



## POWER SYSTEMS



Z8 Encore! 64K Series MCU



## COMPONENTS OF POWER SYSTEMS SUPPORTED

- Rectifiers
- Power Controllers
- Distribution Systems
- Power Control Supervision Modules

## FEATURES THAT SEPARATE US FROM THE REST

- Up to 12-channel, high-resolution 10-Bit Sigma-Delta ADCs for monitoring signals such as temperature, current, and voltage
- Two low-power modes (HALT/STOP), and individual peripheral-level power control modes for optimizing power consumption
- Up to 2 UART interfaces for REMOTE/LOCAL system monitoring, serial rack communication between rectifier modules, and supervision modules or power controllers
- An on-chip I<sup>2</sup>C interface (MASTER MODE) for serial rack communication
- Up to 4 enhanced 16-bit timer blocks, featuring PWM capability to allow Digital-to-Analog conversion

## THE Z8 ENCORE!<sup>®</sup> 64K SERIES

With the emergence of cellular phones and the internet, the worldwide demand for telecommunications, networking, and data communication systems have been steadily increasing. To cater to local and remote system monitoring, communications between various rectifier and supervisor/controller modules require interfaces such as a UART and/or I<sup>2</sup>C. Depending on the end product feature set, these modules can range easily from simple to very complex designs.

ZiLOG's Z8 Encore! 64K Series addresses these market demands with a wide range of 8-bit Flash microcontroller solutions – ranging from 16KB to 64KB of flash memory and up to 4KB of RAM. The Z8 Encore! 64K Series MCU is equipped with key power management features, including support for two main low-power modes (HALT/STOP). This powerful MCU offers up to 12, 10-bit sigma-delta ADCs, and up to 4 enhanced 16-bit timers with Capture/Compare/PWM capabilities for a variety of power system designs (power shelves, power racks, etc.) based on IBA, DPA or ATCA.

## MEETING YOUR POWER SYSTEM DESIGN REQUIREMENTS WITH THE Z8 ENCORE! 64K SERIES

### Low-Power Consumption

Offers many power-saving features by supporting 2 low power modes (HALT, STOP), a crystal oscillator with 3 power settings, and peripheral-level power control modes. The unused peripheral blocks can be disabled individually by software. Depending on the activity level, the microcontroller could be put into either a HALT or STOP mode to optimize and/or maintain the lower power consumption.

### Timers with Capture/Compare/PWM Capabilities

PWM features can be used to generate analog voltages that act as digital-to-analog converters (DAC) for functions including fine tuning or adjusting voltage or current outputs, temperature compensation, etc.

### High-Resolution 10-bit Sigma-Delta ADC

Up to 12 channels, 10-bit ADCs are available for monitoring signals within a power system design such as input/output voltages, currents, temperature, etc.

### Design Flexibility

With up to 64KB Flash memory, and 4KB RAM, the 64K Series addresses your need for system flexibility. With a wide selection of interfaces, including a UART, IrDA-compliant encoders /decoders, SPI and I<sup>2</sup>C (Master Mode), the Z8 Encore! 64K Series allows full communication between power modules or power systems.

### Application Support

ZiLOG offers a wide variety of reference designs, application notes and technical notes to jump-start on new designs or projects, enabling faster time to market.

# Intelligent Power Management Solutions

Z8 Encore!<sup>®</sup> 8-Bit Microcontrollers



## POWER SYSTEMS

Z8 Encore! 64K Series MCU



## BLOCK DIAGRAM

16-64KB Flash	2-4KB RAM	Up to 12 Channels 10-Bit ADC
Four 16-Bit Timers/PWM	20MHz eZ8 <sup>™</sup> CPU	3-Channel DMA
Watch-Dog Timer with RC Oscillator		POR/VBO and Reset Control
SPI, I <sup>2</sup> C, 2 UARTs with IrDA	On-Chip Debugger	Crystal/RC Oscillator
Up to 60 General-Purpose I/O Pins		

## MCU FEATURES

- 20MHz eZ8 CPU core
- Up to 64KB Flash memory with in-circuit programming capability (Flash only)
- Up to 4KB register RAM
- Up to 12-channels, 10-Bit Sigma-Delta ADC
- Two full-duplex 9-bit UARTs with bus transceiver Driver Enable Control
- SPI & I<sup>2</sup>C (Master Mode) peripheral interfaces
- Infrared Data Association (IrDA)-compliant encoder/decoders
- Up to four, 16-Bit timers with capture, compare, and PWM capability
- Watch Dog Timer (WDT) w/internal RC osc.
- 3-Channel DMA
- Up to 60 General-Purpose I/O pins
- Up to 24 interrupts w/configurable priority
- On-Chip Debugger
- Power-On Reset (POR)
- Crystal oscillator w/three power settings and external RC network option
- 3.0-3.6V operating voltage w/5V-tolerant inputs
- 40-, 44-, 64-, 68- & 80-pin packages
- 0° to +70°C (standard), -40° to +105°C (extended), and -40° to +125°C automotive/Industrial temperature ranges

## SYSTEM DIAGRAMS

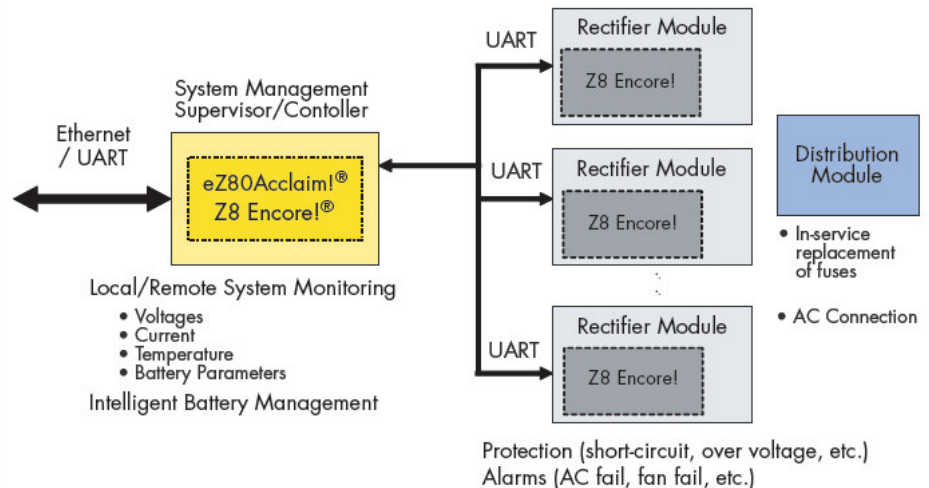

Power System Diagram:  
Power/System Management Supervisor

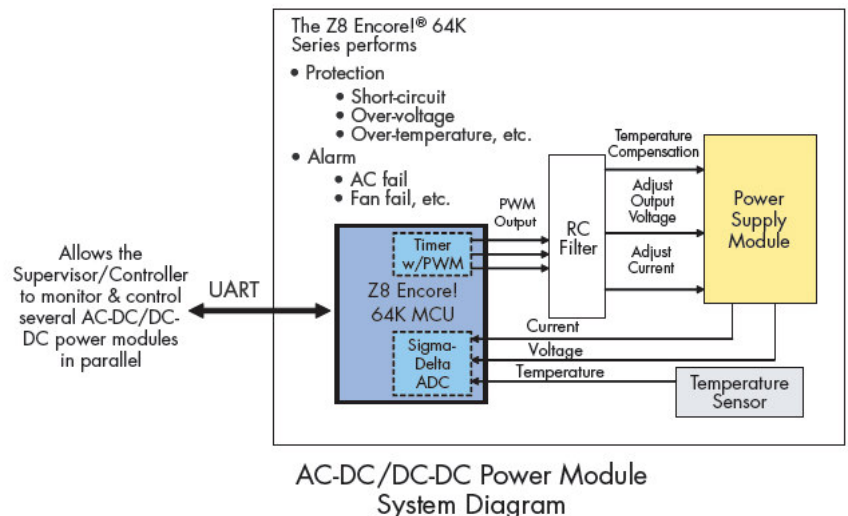

## DEVELOPMENT TOOLS INFORMATION

The **Z8 Encore!<sup>®</sup> 64K Series** Flash microcontroller Development Kit (part #: Z8F64200100KIT) is the low-cost development tool that contains everything you need to evaluate and design your next power solution project.

## FOR MORE INFORMATION

Visit us at [www.zilog.com](http://www.zilog.com) or call us at 1 (866) GO ZiLOG.