



Z86C02/E02/L02, Z86C04/E04/L04, Z86C08/E08/L08

PRODUCT UPDATE TO INTRODUCE 20-PIN SSOP PRODUCTS

UP000301-0800

20-PIN SSOP ADDITION

This Product Update is an addendum to the Z86C02/E02/L02, Z86C04/C08, Z86E04/E08, and Z86L04/L08 Product Specifications to introduce a 20-pin SSOP package.

Two 20-pin SSOP configurations are available, as shown in Figures 1 and 2. The 20-pin SSOP package is illustrated in Figure 3.

FIGURE 1. 20-PIN SSOP PIN CONFIGURATION 1

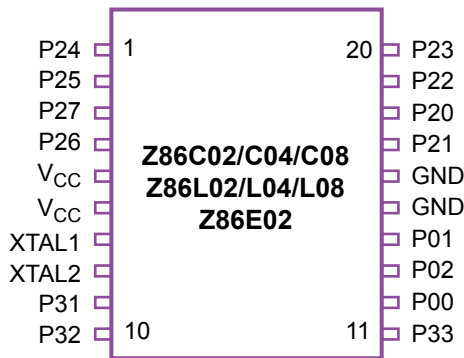

FIGURE 2. 20-PIN SSOP PIN CONFIGURATION 2

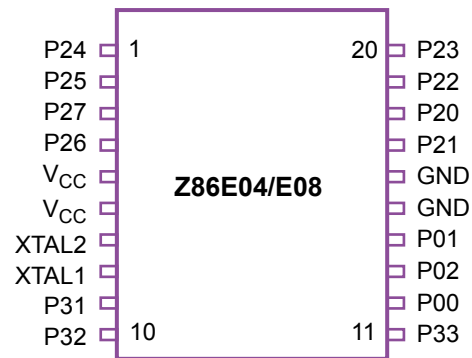
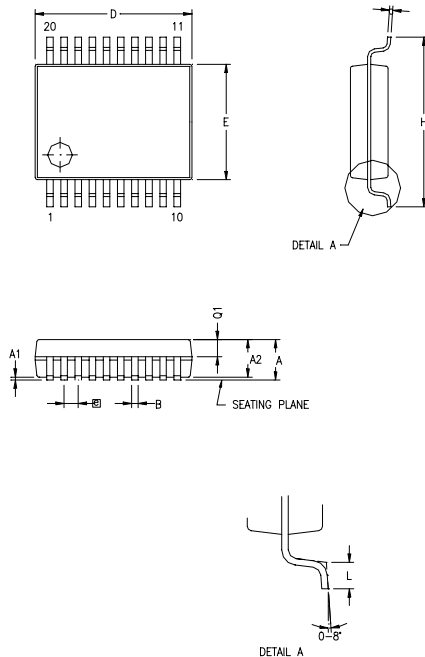

FIGURE 3. 20-PIN SSOP PACKAGE DIAGRAM



SYMBOL	MILLIMETER			INCH		
	MIN	NOM	MAX	MIN	NOM	MAX
A	1.73	1.85	1.98	0.068	0.073	0.078
A1	0.05	0.13	0.21	0.002	0.005	0.008
A2	1.68	1.73	1.83	0.066	0.068	0.072
B	0.25	0.30	0.38	0.010	0.012	0.015
C	0.13	0.15	0.22	0.005	0.006	0.009
D	7.07	7.20	7.33	0.278	0.283	0.289
E	5.20	5.30	5.38	0.205	0.209	0.212
Ⓜ	0.65 BSC			0.0256 BSC		
H	7.65	7.80	7.90	0.301	0.307	0.311
L	0.56	0.75	0.94	0.022	0.030	0.037
Q1	0.74	0.78	0.82	0.029	0.031	0.032

CONTROLLING DIMENSIONS : MM
LEADS ARE COPLANAR WITHIN .004 INCH.

Additional Information

The following documents provide additional information:

- Product Specifications:
 - [Z86C02/E02/L02](#)
 - [Z86C04/C08](#)
 - [Z86E04/E08](#)
 - [Z86L04/L08](#)
- User Manual:
 - [Z8 User Manual](#)
- Emulator Specifications:
 - [Z86CCP01ZEM Emulator](#)
- Internet:
 - [Z8 MCU products](#)