

Schematic Diagrams

Figures 3 and 4 show schematics for the ZMOTION Detection Module II and the ZDM II Evaluation Board, respectively.

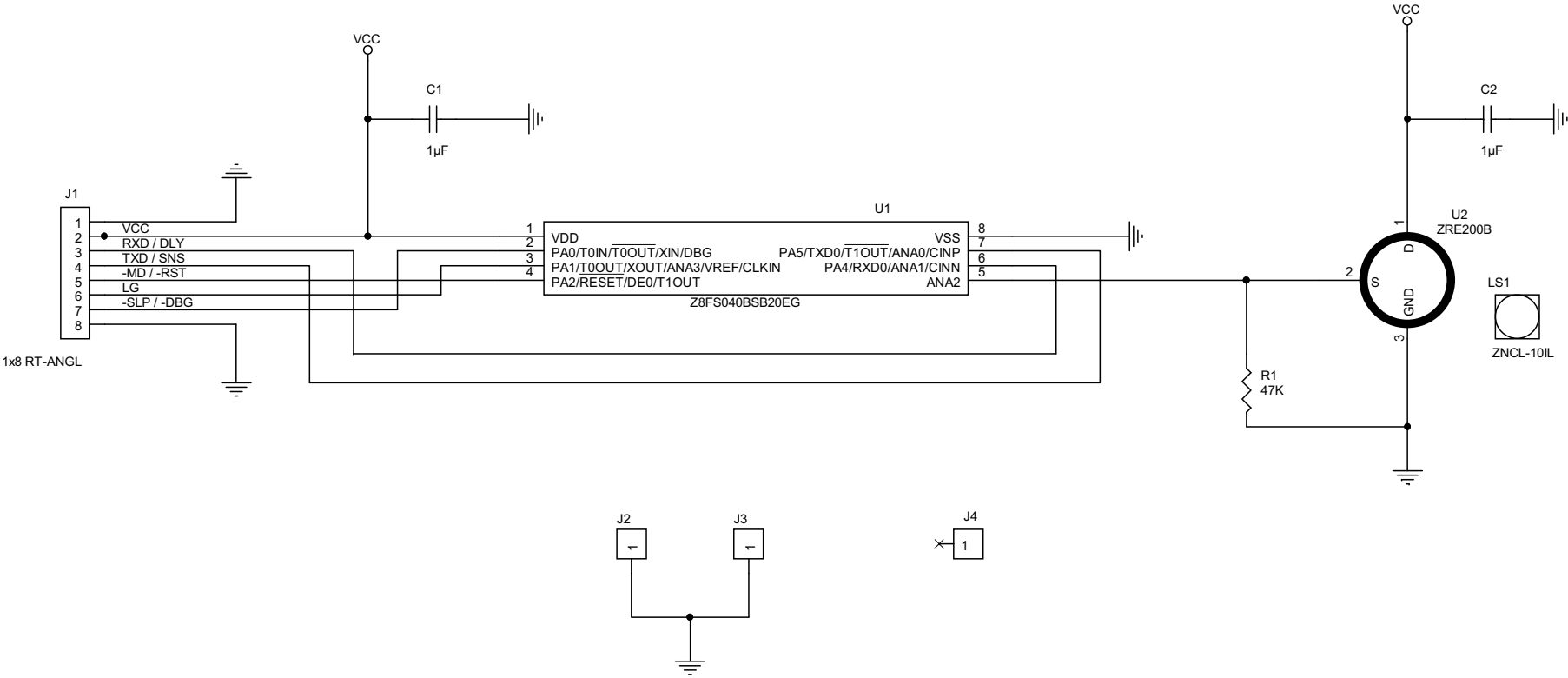

Figure % Schematic Diagram of the ZMOTION Detection Module II

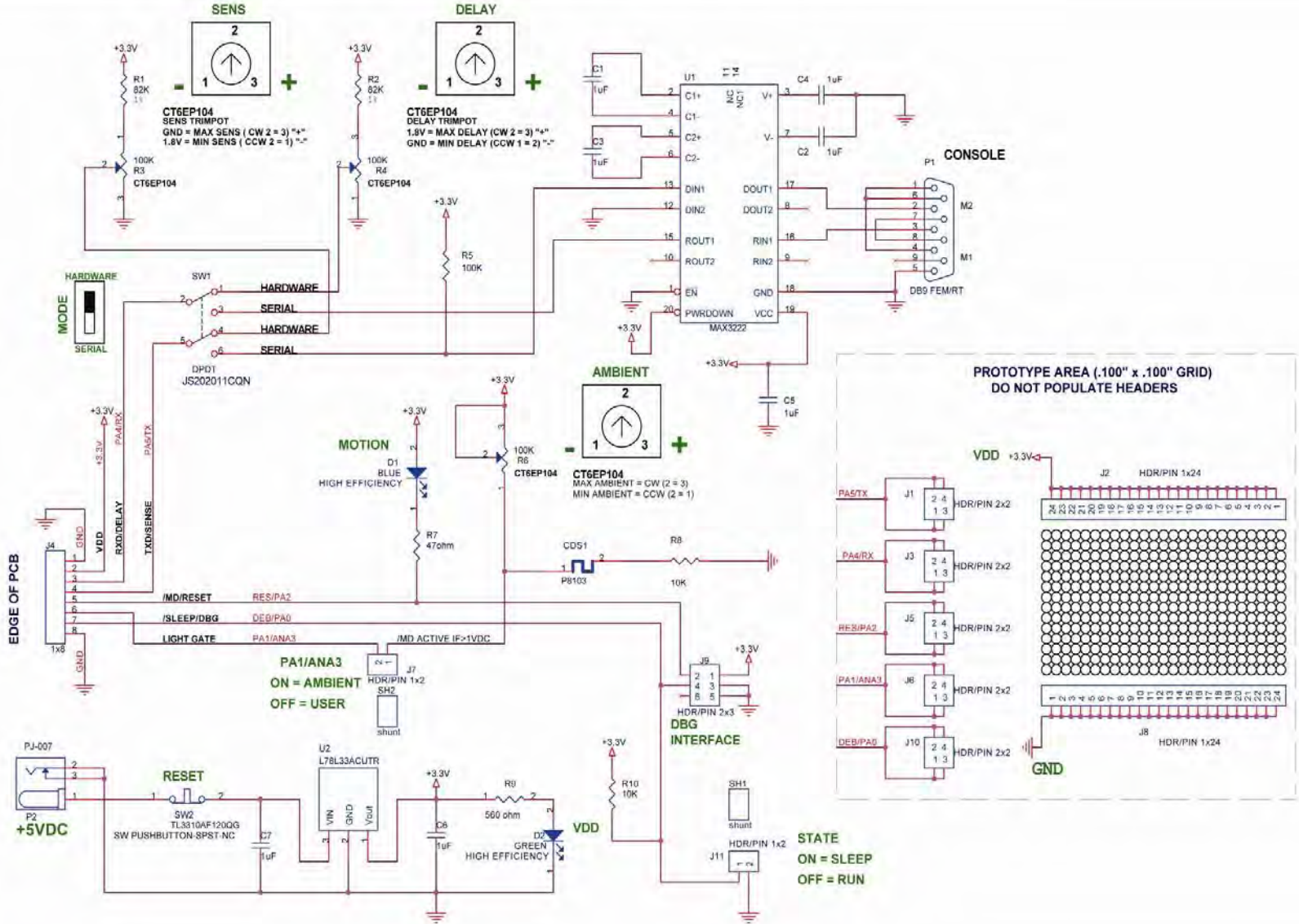

Figure & Schematic Diagram of the ZDMII Evaluation Board