



## **ZNEO32! Family of Microcontrollers**

# **Z32F384 Evaluation Kit**

### **User Manual**

UM027802-0616

**ZNEO32!**  
*32 Bit Microcontrollers*



**Warning:** DO NOT USE THIS PRODUCT IN LIFE SUPPORT SYSTEMS.

---

## LIFE SUPPORT POLICY

ZILOG'S PRODUCTS ARE NOT AUTHORIZED FOR USE AS CRITICAL COMPONENTS IN LIFE SUPPORT DEVICES OR SYSTEMS WITHOUT THE EXPRESS PRIOR WRITTEN APPROVAL OF THE PRESIDENT AND GENERAL COUNSEL OF ZILOG CORPORATION.

### As used herein

Life support devices or systems are devices which (a) are intended for surgical implant into the body, or (b) support or sustain life and whose failure to perform when properly used in accordance with instructions for use provided in the labeling can be reasonably expected to result in a significant injury to the user. A critical component is any component in a life support device or system whose failure to perform can be reasonably expected to cause the failure of the life support device or system or to affect its safety or effectiveness.

### Document Disclaimer

©2016 Zilog, Inc. All rights reserved. Information in this publication concerning the devices, applications, or technology described is intended to suggest possible uses and may be superseded. ZILOG, INC. DOES NOT ASSUME LIABILITY FOR OR PROVIDE A REPRESENTATION OF ACCURACY OF THE INFORMATION, DEVICES, OR TECHNOLOGY DESCRIBED IN THIS DOCUMENT. ZILOG ALSO DOES NOT ASSUME LIABILITY FOR INTELLECTUAL PROPERTY INFRINGEMENT RELATED IN ANY MANNER TO USE OF INFORMATION, DEVICES, OR TECHNOLOGY DESCRIBED HEREIN OR OTHERWISE. The information contained within this document has been verified according to the general principles of electrical and mechanical engineering.

ZNEO32! is a trademark or registered trademark of Zilog, Inc. All other product or service names are the property of their respective owners.

## Revision History

Each instance in this document's revision history reflects a change from its previous edition. To learn more, refer to the corresponding page(s) or appropriate links furnished in the table below.

<b>Date</b>	<b>Revision Level</b>	<b>Description</b>	<b>Page</b>
Jun 2016	02	Corrected pin connections in Figure 3.	<a href="#">5</a>
May 2016	01	Original issue.	n/a

## Overview

Zilog's Z32F384 Evaluation Kit (Z32F3840100KITG) enables developers to start programming projects using the Z32F384 microcontroller, a member of the ZNEO32! Family of MCUs. The kit exposes the ports to allow them to be connected by the user for prototyping and creating proofs of concept.

This Evaluation Kit consists of 5 LEDs, 2 switches, and a USB-to-UART connection for serial communications and powering. The board also includes a standard 20-pin JTAG header.

This user manual provides a description of the Z32F384 Evaluation Board. It includes features of the Z32F384 MCU, schematic diagrams of the board, and kit contents and requirements.

## Kit Contents

The Z32F384 Evaluation Kit contains the following items:

- 1 Z32F384 Evaluation Board
- 1 A (male) to Mini-B USB cable
- 1 ZNEO32! Evaluation Kit flyer

Additional requirements (to be obtained by user):

- JTAG Debugger tool
- Cortex M3 development tools, such as Keil  $\mu$ Vision 5 or IAR Embedded workbench for ARM
- Zilog CMSIS Pack file, available at [www.zilog.com](http://www.zilog.com)
- Z32F384 MCU product specification ([PS0346](#)), available from the Zilog website.

Figure 1 shows the contents of the Z32F384 Evaluation Kit.



Figure 1. The Z32F384 Evaluation Kit

## Z32F384 MCU Features

The Z32F384 MCU includes the following features:

- High performance low-power Cortex-M3 core
- 384KB code Flash memory with cache function
- 16KB SRAM
- 3-Phase PWM with ADC triggering function
  - 2 Channels
- 1.5 MSPS high-speed ADC with sequential conversion
  - 2 units with 16 Channel input
- System fail-safe function by clock monitoring
  - XTAL OSC fail monitoring function
  - System clock Fail monitoring function
- Internal clock sources
  - Internal ring oscillator (1 MHz  $\pm$ 50%)
  - Internal oscillator clock (20MHz  $\pm$ 3%)
  - Internal Phase Lock Loop (PLL) up to 80MHz
- External clock sources
  - External crystal oscillator (4~16MHz)
  - External sub oscillator (32kHz)
- Watchdog timer
- 10 general purpose timer channels
- Timer/capture/PWM mode
- Free run timer
- Various external communication ports:
  - 4 UARTs
  - 2 I<sup>2</sup>Cs
  - 2 SPIs
- High current driving port for UART photo couplers
- Direct Memory Access (DMA) controller with 8 channels
- Debug and emergency stop function
- JTAG and SWD debugger
- Package: LQFP-100 (0.5mm pitch)

- Industrial grade operating temperature (- 40 ~ +85°C)

To learn more about the Z32F384 MCU, refer to the Z32F384 MCU Product Specification ([PS0346](#)).

## Mini Board

Figure 2 shows the Mini Board and Table 1 lists its characteristics.

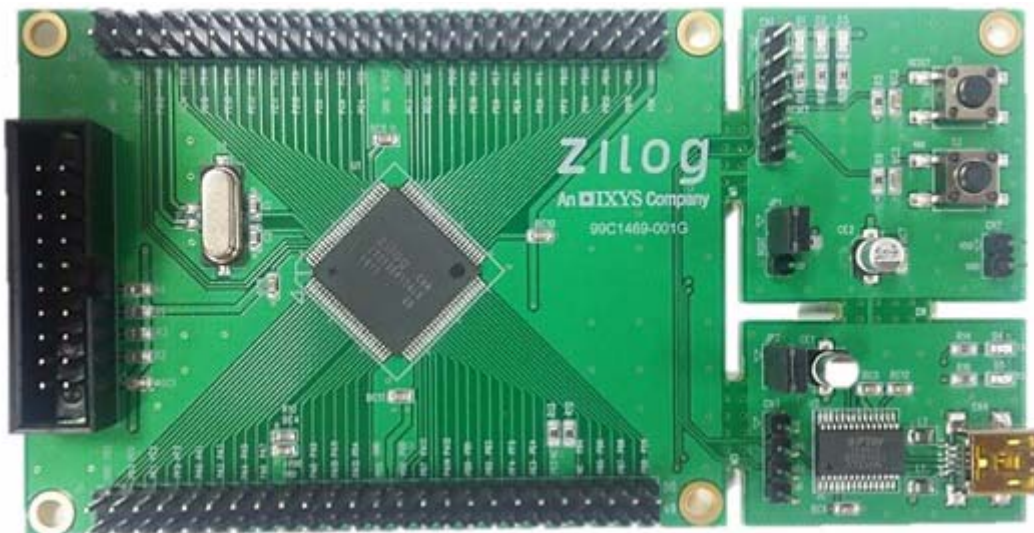

Figure 2. Mini Board

Table 1. Mini Board Characteristics

Contents	Main Characteristics	Note
MCU	Z32F38412ALS	ARM Cortex M3
Operating clock	8MHz	Crystal
ROM	384KB Flash ROM	
RAM	16KB	
Communication port	USB to UART port	Mini-B USB connector
Debugging port	J-Tag	20-pin connector
Input buttons	1 reset, 1 NMI	Tactile switch

Figure 3 displays the Mini Board MCU's external pin connections.

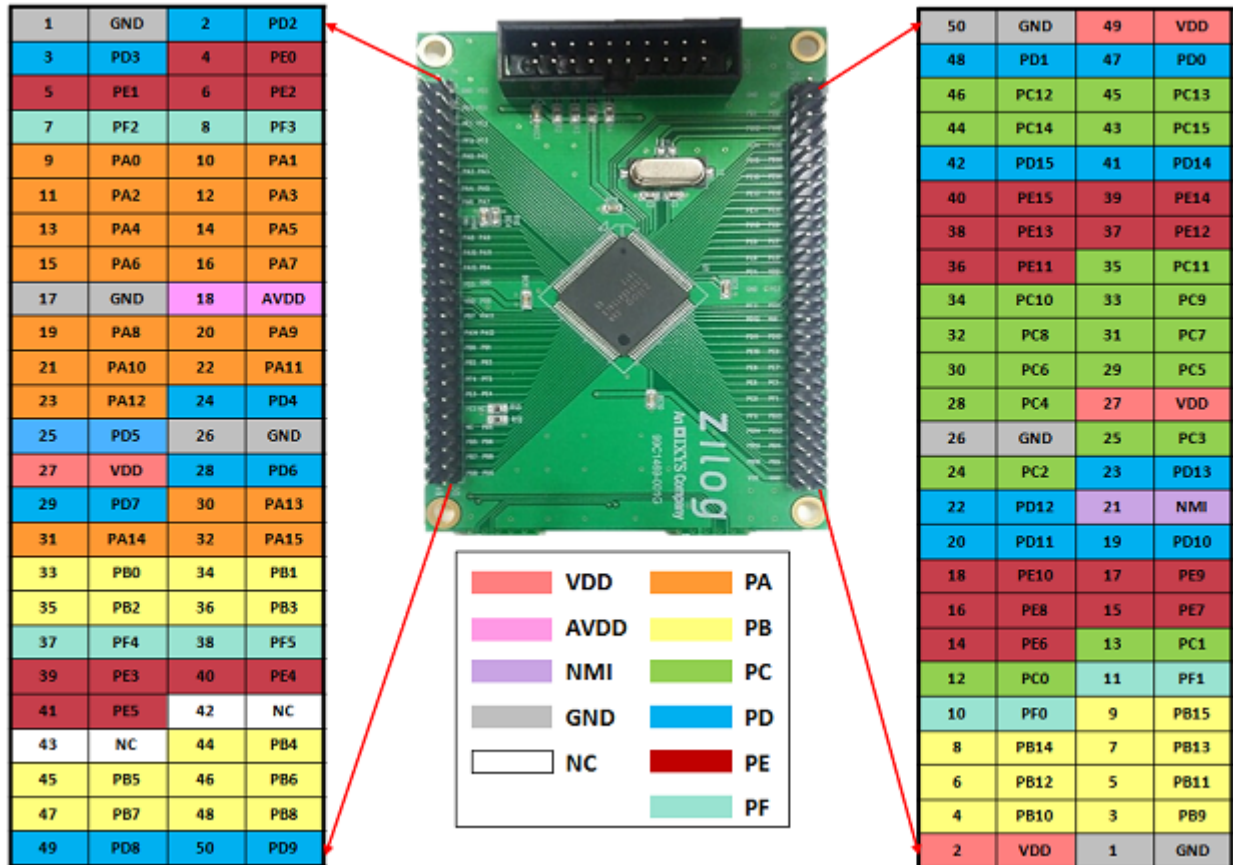

Figure 3. Mini Board MCU's External Pin Connections



The jumper settings are shown in Figure 4.

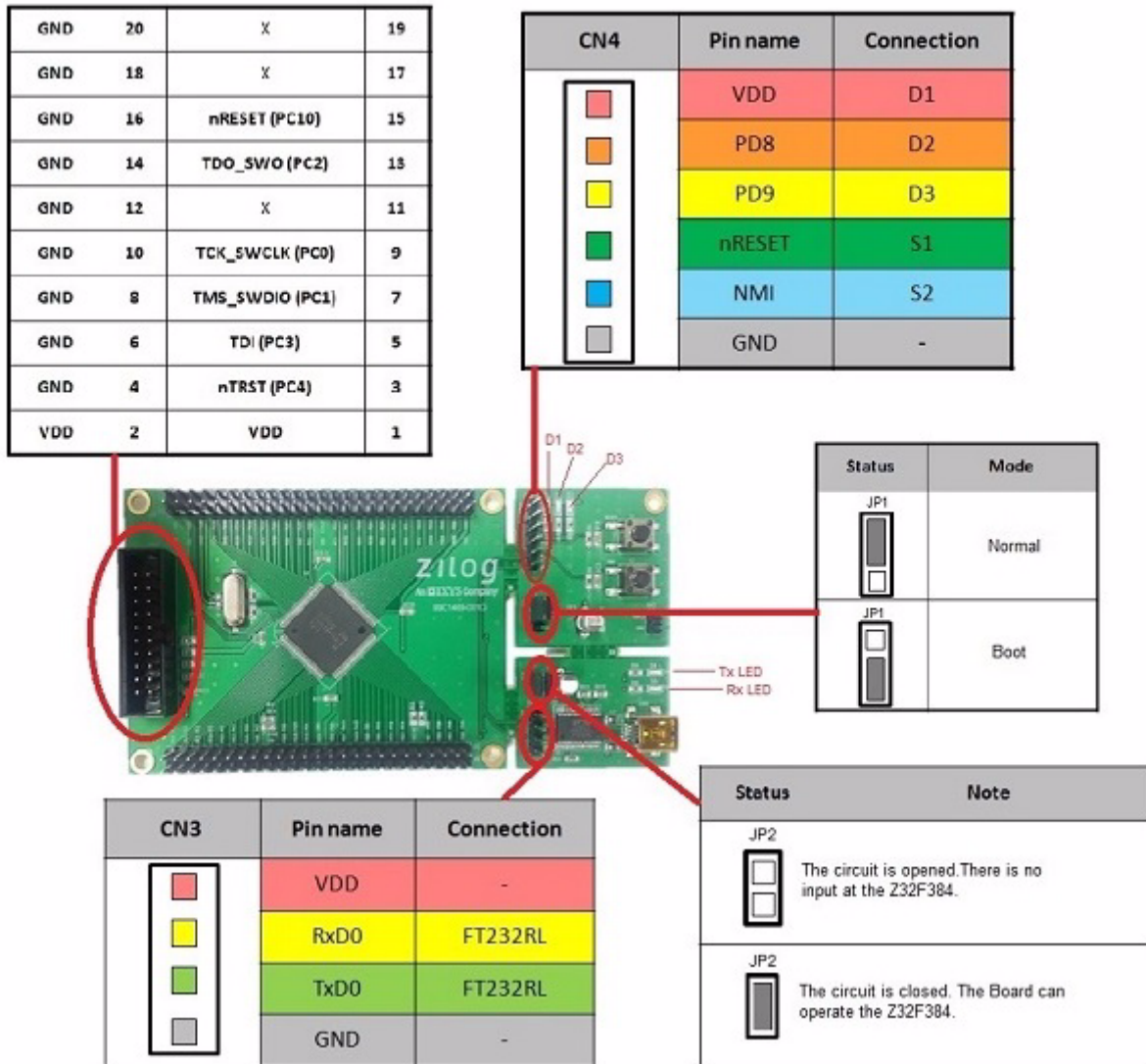

Figure 4. Jumper Settings

## Z32F384 Evaluation Kit Documentation

The documents associated with the Z32F384 Evaluation Kit are listed in Table 2. Each of these documents can be obtained from the Zilog website by clicking the link associated with its Document Number.

**Table 2. Z32F384 Evaluation Kit Documentation**

<b>Document</b>	<b>Description</b>
<a href="#">UM0278</a>	Z32F384 Evaluation Kit User Manual
<a href="#">PS0346</a>	Z32F384 Product Specification
<a href="#">FL0183</a>	ZNEO32! Evaluation Kit Insert

# Appendix A. Schematic Diagrams

Figure 5 presents a schematic diagram of the Z32F384 Evaluation Board with the 100-pin LQFP package MCU.

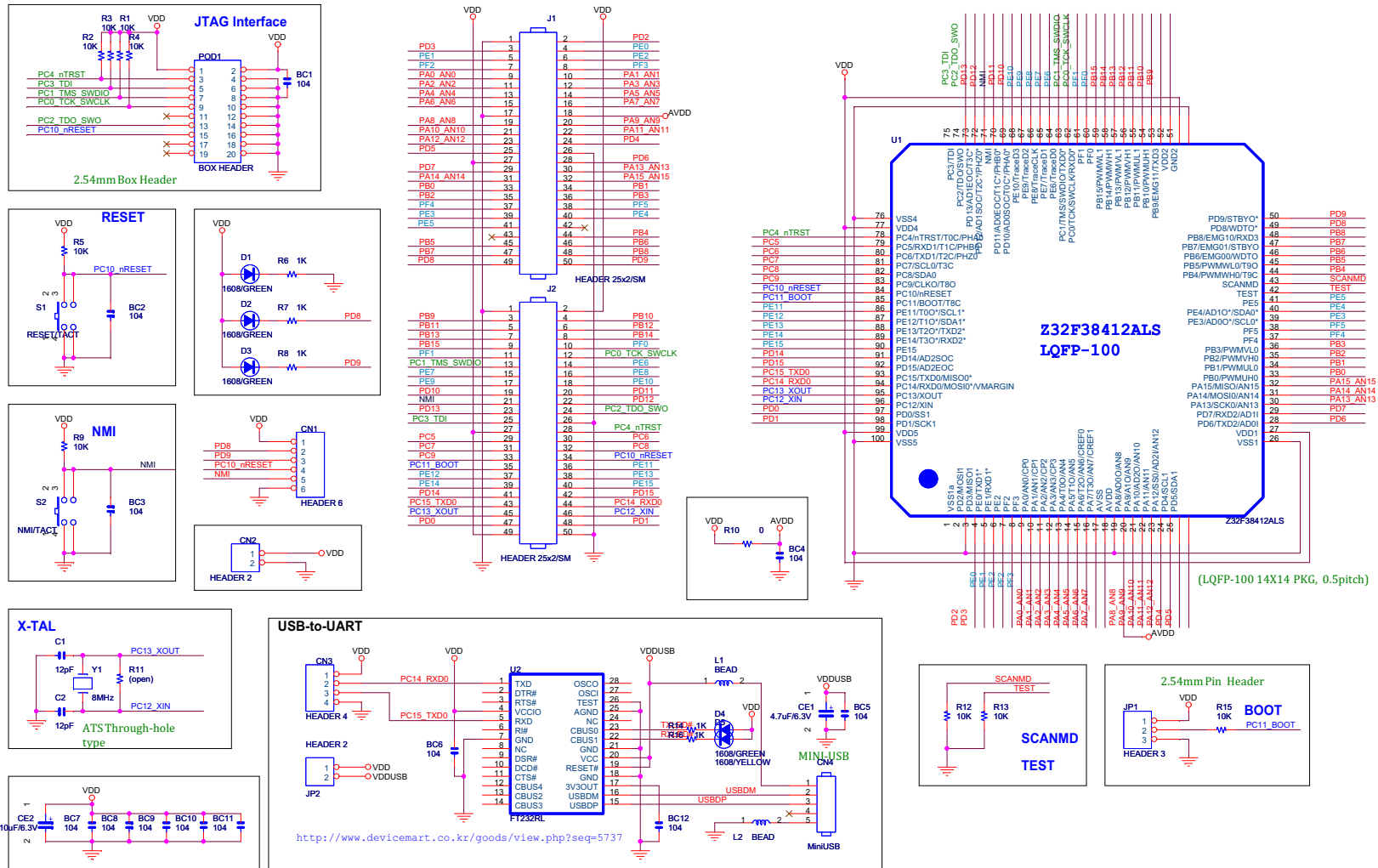

Figure 5. Z32F384 Evaluation Board Schematic Diagram

## Customer Support

To share comments, get your technical questions answered, or report issues you may be experiencing with our products, please visit Zilog's Technical Support page at <http://support.zilog.com>.

To learn more about this product, find additional documentation, or to discover other facets about Zilog product offerings, please visit the [Zilog Knowledge Base](#) or consider participating in the [Zilog Forum](#).

This publication is subject to replacement by a later edition. To determine whether a later edition exists, please visit the Zilog website at <http://www.zilog.com/>